

**INSTRUCTION MANUAL**  
for  
**THE**  
**NATIONAL MODEL**  
**HRO-7**

**RADIO RECEIVING  
EQUIPMENT**

An Outstanding Communications Receiver  
of proven integrity and performance in  
Commercial and Amateur stations.

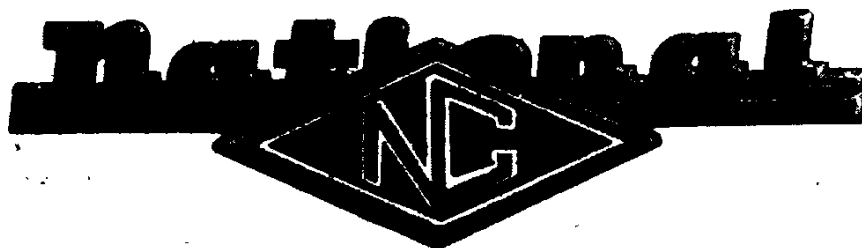

NATIONAL COMPANY, INC.

ESTABLISHED 1914



ENGINEERS AND MANUFACTURERS

CABLE ADDRESS  
"NATCO" BOSTON

61 SHERMAN STREET  
MALDEN 48, MASS.

August 29, 1951

Mr. James Brentain  
62 Appleton Ave.  
San Francisco, California

Dear Sir:

We are in receipt of your letter of August 12 requesting information for your HRO receiver. We are enclosing the HRO 7 Instruction Book and do believe that if you wire your limiter circuit in a similar fashion you will have satisfactory results.

You mentioned that the S meter frequently sticks, we would suggest that you remove the S meter from the case and open the stops so this condition will not exist. This is a simple adjustment and you should have no trouble at all in correcting it.

Yours very truly,

NATIONAL COMPANY, INC.

Frank Lopez  
Service Manager

FL:eld

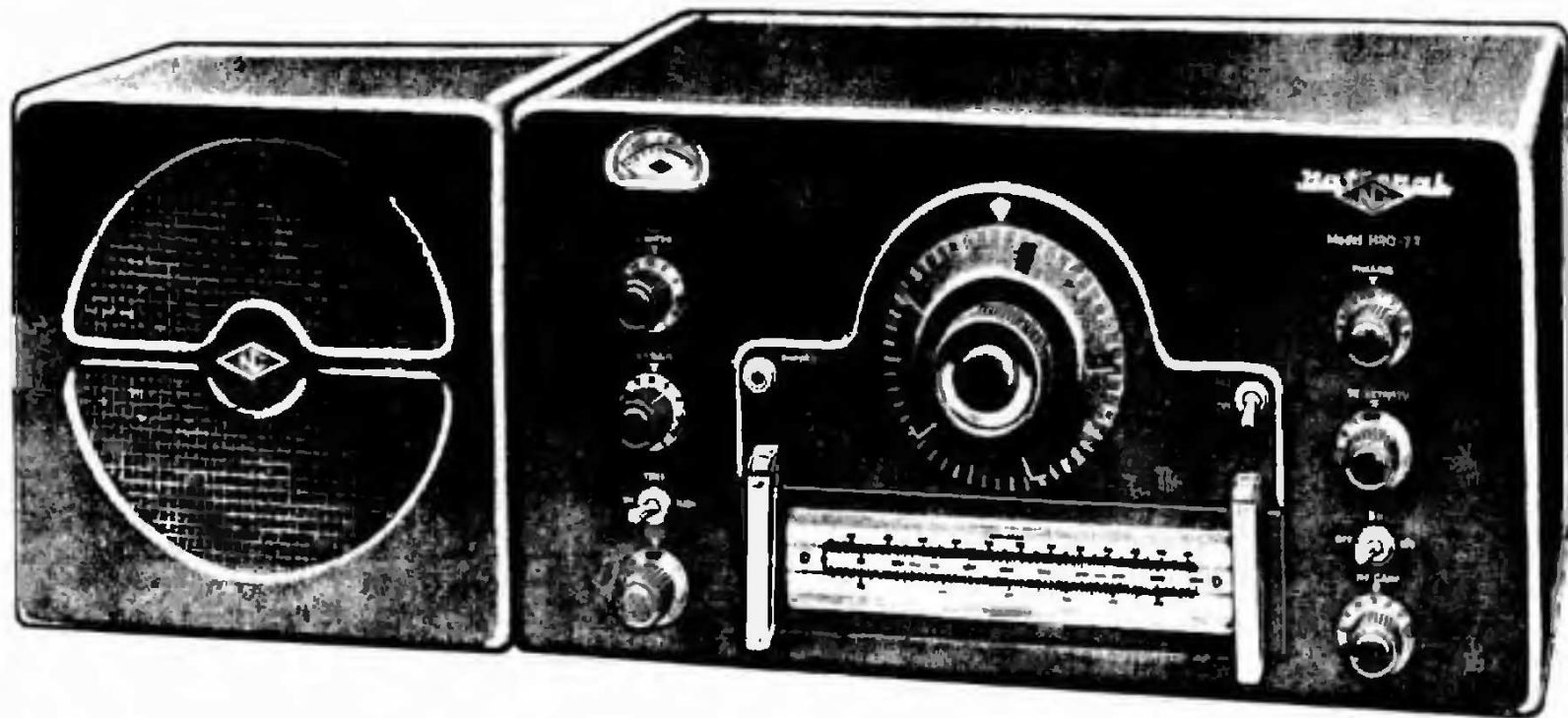

## HRO-7 Receiver

### FEATURES . . .

- Tuning Range 50-430 Kcs. and 480-30,000 Kcs.
- Nine Tuning Bands Accurately Calibrated
- Calibrated Bandsread for 10-11 20, 40 and 80 meter Amateur Bands
- High Sensitivity
- Excellent Signal to Noise Ratio
- New, Flexible Crystal Filter
- Automatic, Adjustable Threshold, Double Action Noise Limiter
- Accessory Connector Socket
- Temperature Compensation
- Plug-In Coils for Efficiency and Flexibility
- Separate Power Supply and Speaker

*National Company, Inc.*

# THE HRO-7 RADIO RECEIVER

## SECTION 1. DESCRIPTION

### 1-1. General

The HRO-7 Radio Receiver is a twelve tube high-frequency superhetrodyne for the reception of code and phone signals throughout its frequency range of 50 to 430 Kcs., and 480 to 30,000 Kcs. Long an outstanding and proven performer in Communication and Amateur services, this new series of HRO-7 Receivers features many new refinements emanating from the latest advances in receiver circuitry and design. A new automatic, adjustable threshold, double action noise limiter effectively reduces interference caused by external noise pulses. Two new miniature type tubes, a 6C4 high-frequency oscillator and an OA2 voltage regulator, are employed to give a high order of oscillator stability. The addition of an Accessory Connector Socket, Tone Control, plus other electrical and mechanical revisions give this new HRO greater flexibility and adaptability. A 6 position crystal filter, maximum bandspreading of the Amateur bands, and an excellent signal-to-noise ratio continue to make the HRO a dependable Receiver, capable of maintaining communications despite the most adverse conditions. The HRO-7 is housed in a new cabinet styled in a modern manner with an attractive gray finish.

A complete equipment consists of a receiver, power supply, loud-speaker and plug-in coil set types A, B, C and D. Coil set types E, F, G, H and J may be obtained in addition, as desired.

### 1-2. Circuit

The circuit employed on all bands comprises two tuned stages of radio frequency amplification, a tuned first detector, a high-frequency oscillator employing a tube separate from the first detector tube, a first intermediate frequency amplifier stage employing a variable-selectivity crystal filter and a conventional second intermediate frequency amplifier stage both operating at 456 kilocycles, a combined second detector - automatic volume control stage, an automatic adjustable-threshold series valve noise limiter, a first audio

amplifier stage, an audio output stage and a beat frequency oscillator coupled to the second detector to provide for C.W. reception. A voltage regulator tube is used to regulate the plate supply to the high frequency oscillator tube.

### 1-3. Antenna Input

The Receiver is designed for operation with a single wire antenna or antennae employing transmission lines having impedances of 70 ohms or more. The actual antenna input impedance is between 300 and 600 ohms depending on the received frequency.

### 1-4. Tube Complement

The HRO-7 Receiver is supplied complete with tubes which are tested in the Receiver at the time of alignment.

The tubes employed are as follows:

First R.F. Amplifier.....	6K7
Second R.F. Amplifier.....	6K7
First Detector.....	6J7
High Frequency Oscillator.....	6C4
First I.F. Amplifier.....	6K7
Second I.F. Amplifier.....	6K7
Diode Detector, A.V.C.....	6H6
Noise Limiter.....	6H6
First A.F. Amplifier.....	6SJ7
Audio Output.....	6V6GT/G
Beat Frequency Oscillator.....	6J7
Voltage Regulator.....	OA2

### 1-5. Tuning System

The frequency coverage of the HRO-7 is covered in nine bands as follows:

#### COIL SET GENERAL COVERAGE BANDSPREAD

A	14.0 - 30 Mc.	27.0-30.0 Mc.
B	7.0 -14.4 Mc.	14.0-14.4 Mc.
C	3.5 - 7.3 Mc.	7.0- 7.3 Mc.
D	1.7 - 4.0 Mc.	3.5- 4.0 Mc.
E	900 -2050 Kc.	
F	480 - 960 Kc.	
G	180 - 430 Kc.	
H	100 - 200 Kc.	
J	50 - 100 Kc.	

As shown above plug-in coil set types A, B, C and D provide bandspread coverage

of the 10-11, 20, 40 and 80 meter amateur bands. The B, C and D bands are spread out so as to cover 400 dial divisions, while the A band is spread 430 divisions on the 500 division main tuning dial. This is accomplished by switching small capacitors in series with each section of the main tuning capacitor, thus reducing its effective capacity range. All coil sets are aligned in the Receiver using crystal controlled test oscillators assuring precise calibration.

The micrometer type MAIN TUNING dial drives the four gang main tuning capacitor through a worm drive having a reduction ratio of approximately 20 to 1. Backlash is eliminated by the use of a spring-loaded split worm wheel which assures positive drive in either direction at all times. This dial has an effective scale length of approximately twelve feet and is calibrated from zero to 500. The chart appearing on the front of each plug-in coil set is fitted with a linear scale corresponding to the dial markings and a parallel frequency scale which enables the operator to readily determine the frequency of any particular dial setting. Lever type handles are mounted on the front panel at each end of the plug-in coil set enclosure to facilitate the changing of coil sets. These handles make coil set changing effortless and sure; when the handles are depressed to their maximum vertical position positive contact is made between the coil set and the Receiver brushboard.

#### 1-6. Noise Limiter

The new noise limiter in the HRO-7 is the automatic, adjustable-threshold, series valve type. This limiter is double acting -- limiting noise on both positive and negative peaks and is equally effective on both C.W. and phone reception. Its usefulness is most appreciated on the higher frequency bands of the Receiver where automobile ignition noise and other high frequency disturbances are effectively suppressed.

#### 1-7. Crystal Filter

The crystal filter, located in the first intermediate frequency amplifier

stage, is extremely flexible and of most efficient design. A six-position selectivity control and a crystal phasing control are front-panel mounted for adjustment of the crystal filter. Figure No. 1 shows the selectivity characteristics of the Receiver for each of the six positions of the selectivity control. The crystal filter may be used for either C.W. or M.C.W. reception; any degree of selectivity from true single-signal to broadcast reception being available. Operation of the phasing control provides for easy suppression of interfering signals which may produce objectionable heterodynes.

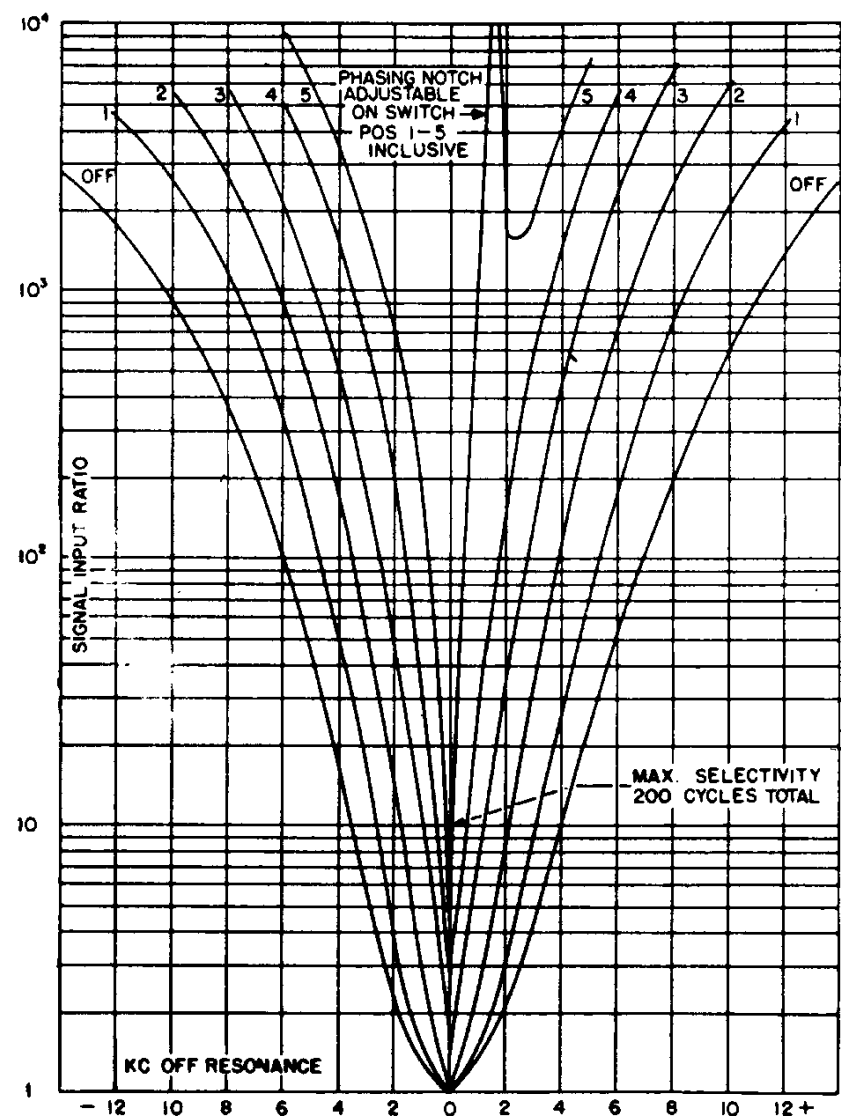

Figure No. 1. Crystal Filter Selectivity Curves.

#### 1-8. Tone Control

A two position TONE control (High-Low) is provided to select the desired frequency characteristic of the audio output. The "Low" setting of this control will aid the operator in receiving weak signals through interference.

**1-9. Accessory Connector Socket**

A socket, S-2, of the standard octal type is mounted at the rear of the Receiver to permit external connection of various accessories such as a narrow-band F.M. adaptor, crystal calibrator, phonograph, microphone or high-frequency converter. A two-position switch, X-8, is mounted adjacent to this socket marked PHONO-RADIO. In the RADIO position all Receiver circuits function normally and connection to the Accessory Connector Socket of equipment such as a crystal calibrator or high-frequency converter may be made. In the PHONO position the second detector portion of the Receiver circuit is rendered inoperative. The PHONO position can be used for the connection of an F.M. adaptor, or phonograph. The input circuit for connection of a phonograph is high-impedance and feeds into the high gain 6SJ7 first audio amplifier stage. The AUDIO GAIN and TONE controls are operative with this connection.

The drawing of the Accessory Connector Socket on the Schematic Diagram shows the various connections made to the pins of this socket and the voltages available. An octal plug termination on the accessory, wired to mate with the proper pins on the Accessory Connector Socket, makes an ideal arrangement for quick and sure connection to the Receiver.

**1-10. Signal Strength Meter**

Signal input readings are indicated in "S" units from 1 to 9 in 5 db. steps and in db. above S-9 from 0 db. to 40 db. on the panel mounted signal strength meter. A reading of S-9 is obtained with an antenna input of approximately 50 microvolts. Accurate signal input readings from 0.5 microvolts to 5000 microvolts are possible. The meter employs a 0-1 milliamperere movement and is connected in a bridge circuit.

**1-11. Audio Output**

Two audio output circuits are provided. Loud-speaker terminals in the form of a five prong socket are located at the rear of the Receiver and a phone jack is mounted on the front panel. Normally, the plate

circuit of the output tube is brought directly to the output socket for connection to a separate permanent-magnet loud-speaker. The loud-speaker must have an impedance of from 5000 to 7000 ohms to properly load the output tube. The output transformer in this case is mounted on the loud-speaker and its primary carries the plate current of the output tube. The phone jack is wired so as to silence the loud-speaker when the phone plug is inserted. The headphone output load impedance is not critical and varying types of headphones may be used including crystal types, as no direct current flows through the phones.

**1-12. Temperature Compensation**

The HRO-7 is compensated for frequency drift due to temperature changes occurring in circuits which may detune the receiver from the desired signal. The cause of most objectionable frequency drift is the change of inductance of the high-frequency oscillator coil as heat from the tubes causes the interior of the Receiver to increase in temperature. This undesirable heating effect of the R.F. coils is minimized by the position of the plug-in coil sets in that they plug in at the bottom of the Receiver underneath the chassis in a separate shielded compartment. A further safeguard against frequency drift is provided for on bandspread operation. The heat dissipated in the high frequency oscillator tube may change the inter-electrode capacity of the tube and thus cause frequency drift. To offset this effect a small negative temperature coefficient capacitor is placed adjacent to the high-frequency oscillator tube to compensate for any change caused by the internal heating of the tube.

**1-13 Power Supply**

The Receiver can be used with the 697 Power Unit for 115 or 230 volt, 50 to 60 cycle A.C. operation or the 686S Power Unit for 6 volt D.C. operation. The Power Units are conservatively rated for use with the Receiver and will give long, trouble-free life. See Section 6-3 for Typical Operating Currents and Voltages with the HRO-7.

**1-14. Loud-speaker**

RFSH or MCR Loud-speakers in rack or table mounting styles respectively can be used with the Receiver. These are permanent magnet type loud-speakers and have an output transformer which provides a proper impedance match for the output tube to the loud-speaker voice coil. This matching transformer has a primary imped-

ance of 5000 ohms. In special models of the Receiver, an output transformer is mounted within the Receiver itself. In this case, the loud-speaker matching transformer must have a primary impedance which matches the Receiver output transformer secondary impedance. External means for supplying field excitation will be necessary if a dynamic speaker is to be used with the Receiver.

**SECTION 2. INSTALLATION****2-1. Arrangement**

The Receiver, Power Unit and Loud speaker may be arranged in any desired position although it is not recommended that the loud-speaker be placed on top of the Receiver as undesirable microphonics may result. Neither Power Unit nor Loud-speaker should be placed near the antenna terminals.

**2-2. Antenna Recommendations**

The radio frequency input of the Receiver is arranged for operation from either a single-wire antenna, a doublet antenna, or other types employing transmis-

sion lines having impedances of 70 ohms or more. There is an antenna terminal panel at the rear of the Receiver with three screw-type terminals marked A, A and G respectively. A link is provided on the antenna terminal panel to allow connection of two-wire or single-wire type antennae to the Receiver.

For best impedance matching to the Receiver input circuit an antenna with a 300 to 600 ohm transmission line is recommended. The antenna should be cut to the proper length for the most used frequency. The antenna transmission line feeders should be connected to the two antenna terminals marked A; the grounding link is

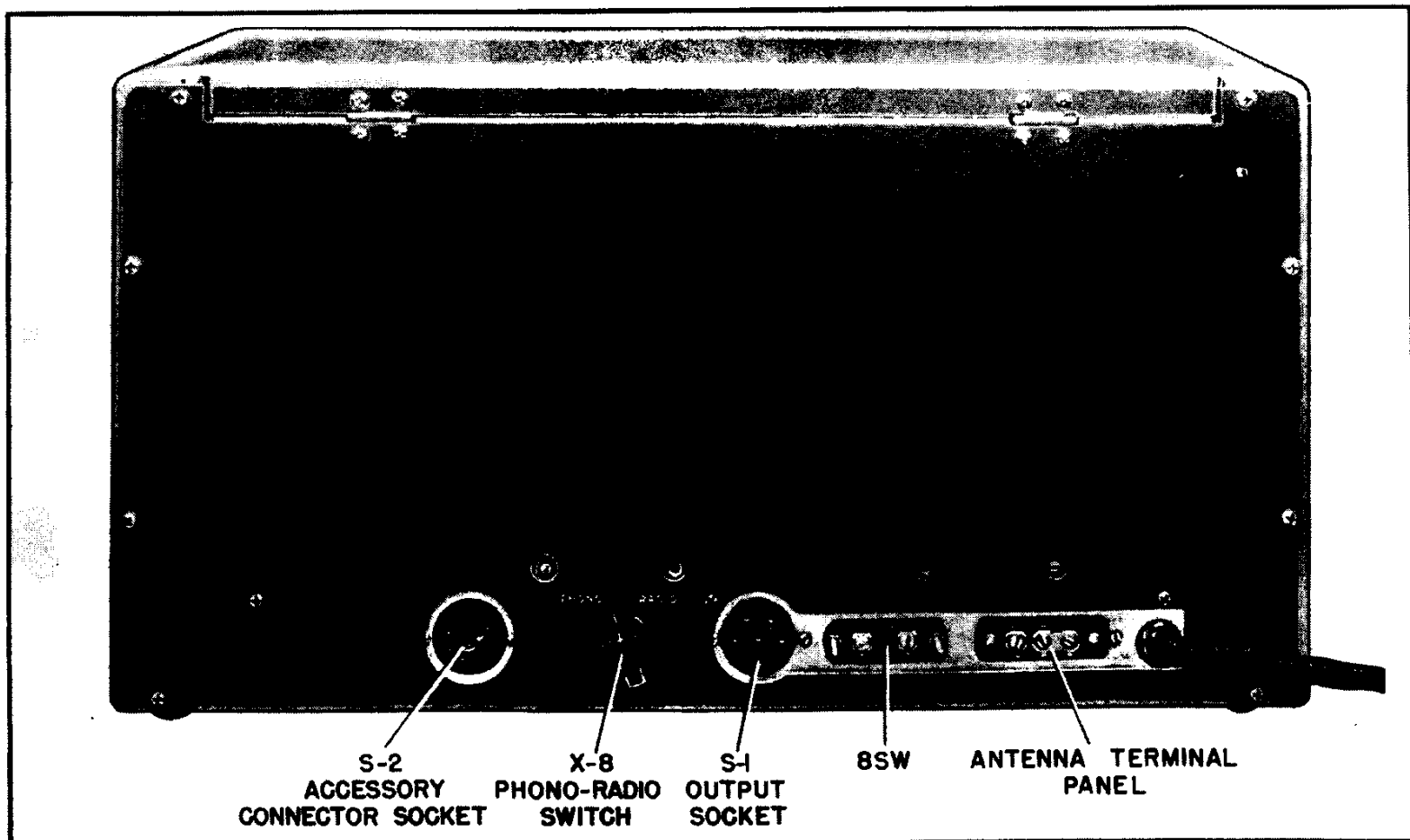

Figure No. 2. Rear View of Receiver (BSW Shield Removed)

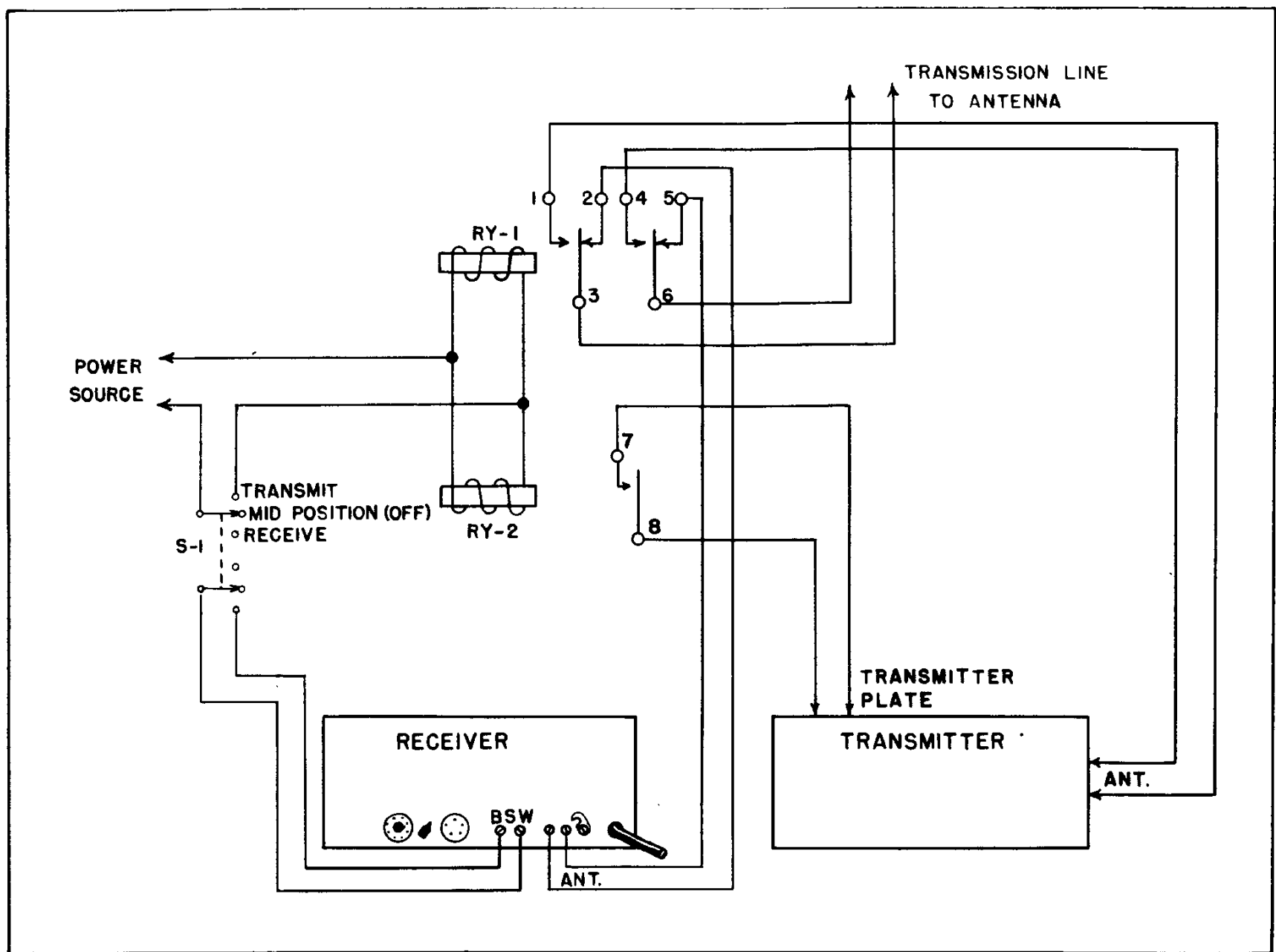

Figure No. 3. Typical Antenna Switching System

not used. It must be remembered, however, that an antenna installation of this type will have maximum efficiency over a band of frequencies near that frequency for which it is designed and will be most useful in installations where the Receiver is tuned to one frequency or band of frequencies. For other frequencies, it would be desirable to connect the two transmission line leads together at the antenna terminal at the left of the antenna terminal panel, grounding the other terminal by means of the link. The antenna is thus utilized as a single wire type.

The most practical antenna for use in installations where the Receiver is to be used over a wide range of frequencies is the single-wire type. An antenna length of from 50 to 100 feet is recommended. The antenna lead-in should be connected to the antenna terminal marked A at the left of the antenna terminal panel; the other term-

inal marked A should be grounded by means of the link.

In an installation where the Receiver is to be used as the receiving unit in a transmitting station the most efficient operation will result from use of the transmitting antenna as receiving antenna also. This is especially true if the transmitting antenna is of the multi-element, directional type since the same antenna gain is available for both receiving and transmitting - a very desirable condition. Any transmission line of 70 ohms impedance or more may be used. For switching the antenna from Receiver to transmitter, an antenna change-over relay should be used. A double pole, double throw relay possessing good high-frequency insulation is suitable. A second relay and a three position switch may be used to control the transmitter plate supply and the Receiver B+ circuits. This second relay should be a single pole,



single throw type having one normally open pair of contacts. The schematic diagram of this type of control circuit is shown in Figure 3. With S-1 in the receive position the antenna transmission line is connected to the Receiver by contacts 2, 3, 5 and 6 on relay RY-1; the B+ circuit of the Receiver is completed by the switch. (The B+ switch on the Receiver should be at B+ OFF). With the switch in the transmit position RY-1 contacts 1, 3, 4 and 6 are closed transferring the antenna transmission line to the transmitter; contacts 7 and 8 of relay RY-2 close to complete the plate supply circuit to the transmitter. Contacts 7 and 8 of relay RY-2 should be in series with the primary of the transmitter plate supply transformer. Thus, the station is in the receiving condition with switch S-1 in the receive position and in the transmitting condition with S-1 in the transmit position. With S-1 in the mid-position the Receiver B+ circuit and transmitter plate supply circuit are both open thus permitting coil set changing in the Receiver and transmitter. In the mid-position the Receiver B+ circuit is controllable by the B+ switch on the front panel of the Receiver.

When a doublet antenna is used, the antenna feeders or balanced transmission line are connected to the two terminals marked A. The grounding link is not used.

The inner conductor of a concentric transmission line should be connected to the terminal marked A at the left of the antenna terminal panel. The outer conductor should be connected to the other terminal marked A and grounded by means of the link to G.

In some cases where a doublet antenna is used with a low impedance concentric or other type transmission line it may be necessary to re-trim the first R.F. amplifier at the high end of each band to provide a better impedance match between antenna and receiver input circuit. Paragraph 4-5 describes this procedure.

### 2-3. AC Operation

After unpacking the HRO-7 Receiver and associated equipment, proceed as follows:

- (1) Make sure all tubes are firmly

seated in their sockets and that all grid grips are securely in position.

- (2) Make sure the plug-in coil set in the Receiver is firmly in position by pressing down the lever-type handles on the front panel to their maximum vertical position.
- (3) Make sure the RADIO-PHONO switch at the rear of the Receiver is set at the RADIO position (right-hand).
- (4) Connect antenna as recommended in Section 2-2.
- (5) Insert the Receiver power plug into the output socket on the Power Unit.
- (6) Insert the five prong loudspeaker plug into the audio output socket at the rear of the Receiver.
- (7) Connect Power Unit line cord to proper source of voltage. The Primary Selection switch, S101, (normally set at 115 volts) must be at the position corresponding to the line voltage to be used i.e. 115 or 230.
- (8) Set controls as recommended in Section 3 for the reception of signals.

### NOTE

Where the Receiver is located in the R.F. field of a relatively powerful transmitter, it is advisable to provide some means of preventing damage to the Receiver R.F. coil. If a separate receiving antenna is used a means of disconnecting or grounding it during transmission periods should be provided.

### 2-1. Battery Operation

The Receiver is readily adaptable to emergency or portable operation, or operation in locations where 115 or 230 volt A.C. power is not available. It may be operated directly from batteries or a National Type 686S Power Unit may be used for operation from a 6 volt storage battery. The Type 686S Power Unit draws 6.5 amperes at 6 volts when furnishing power to the Receiver. Battery drain may be decreased for headphone operation by removing the

6V6GT/G output tube from its socket. In this case, the Type 686S Power Unit draws 5.5 amperes at 6 volts.

The Schematic Diagram, Figure 8, shows a pin view of the Receiver power plug, thus providing the information necessary for wiring batteries to an auxiliary four-prong socket. The regular Receiver power plug may be inserted into this auxiliary socket to complete the power circuit. The normal B voltage required for operation of the Receiver is 240 volts at which voltage the Receiver draws 85 milliamperes. Satisfactory headphone operation will result with a B voltage as low as 180 volts. The B battery life may be increased in this instance by removing the 6V6GT/G output tube from its socket as it is not used for headphone operation. With the output tube removed

from its socket, the Receiver will draw 32 milliamperes at 180 volts. With the output tube in operation the B battery drain is 60 milliamperes at 180 volts. To conserve battery power the Receiver power plug should be removed from the auxiliary battery socket when the Receiver is not being used. If greater convenience is desired, a single pole, single throw switch may be wired in series with the A<sup>+</sup> lead to the battery to turn off the heater supply. If an A battery switch is used it is important that both the external A<sup>+</sup> switch and Receiver B<sup>+</sup> switch be turned OFF to conserve battery power when the Receiver is not being operated. The Receiver B<sup>+</sup> switch will serve as a stand-by switch during transmission periods the same as for A.C. operation.

### SECTION 3. OPERATION

#### 3-1. Controls

The MAIN TUNING dial is arranged so that the frequency to which the Receiver tunes increases as the dial reading increases. Each coil set is provided with a calibration chart showing the relationship between dial reading and frequency. An additional scale for bandspread calibration is provided on the calibration chart of coil sets which include the bandspread feature. Observation of each coil set tuning chart will show that the calibration is very nearly linear which eliminates considerable reference to the coil charts.

The R. F. GAIN control serves to adjust the amplification of the second R. F. first I. F. and second I. F. amplifier stages. Maximum sensitivity is obtained by rotating the control knob to the extreme clockwise position, or 10, on its circular scale. At this setting the S-Meter switch is closed connecting the S-Meter into the circuit. At this position (10) all tubes are operating at maximum gain with minimum bias. As the control is turned counter-clockwise, increasing bias is applied to the second R. F., the first I. F. and the second I. F. tubes, thus reducing their amplification.

The B<sup>+</sup> ON-OFF switch is connected

in the positive lead of the power supply circuit and its purpose is to shut off the Receiver during periods of transmission or WHEN CHANGING COIL SETS. This last function is important. The B<sup>+</sup> circuits are completed when this switch is pushed to the right. Connected in parallel with the B<sup>+</sup> switch and mounted at the rear of the chassis is a pair of contacts, marked B. S. W., intended for use with relay control of the Receiver. The B. S. W. panel is covered by a metal shield to prevent accidental contact with the terminals by the operator. Two slots are provided in this shield to bring out wires to connect to an external switch or relay. Care should be taken that these wires for external connection do not short to the B. S. W. shield.

The PHASING and SELECTIVITY controls are a part of the crystal filter. When the SELECTIVITY control is set at OFF, the crystal is switched out of the circuit. With the crystal switched out, the PHASING control has little influence on the Receiver performance. With the SELECTIVITY control knob set at any point between 1 and 5, inclusive, the crystal filter is in operation, selectivity increasing as the knob is progressively advanced to position 5. The PHASING control is then used to balance

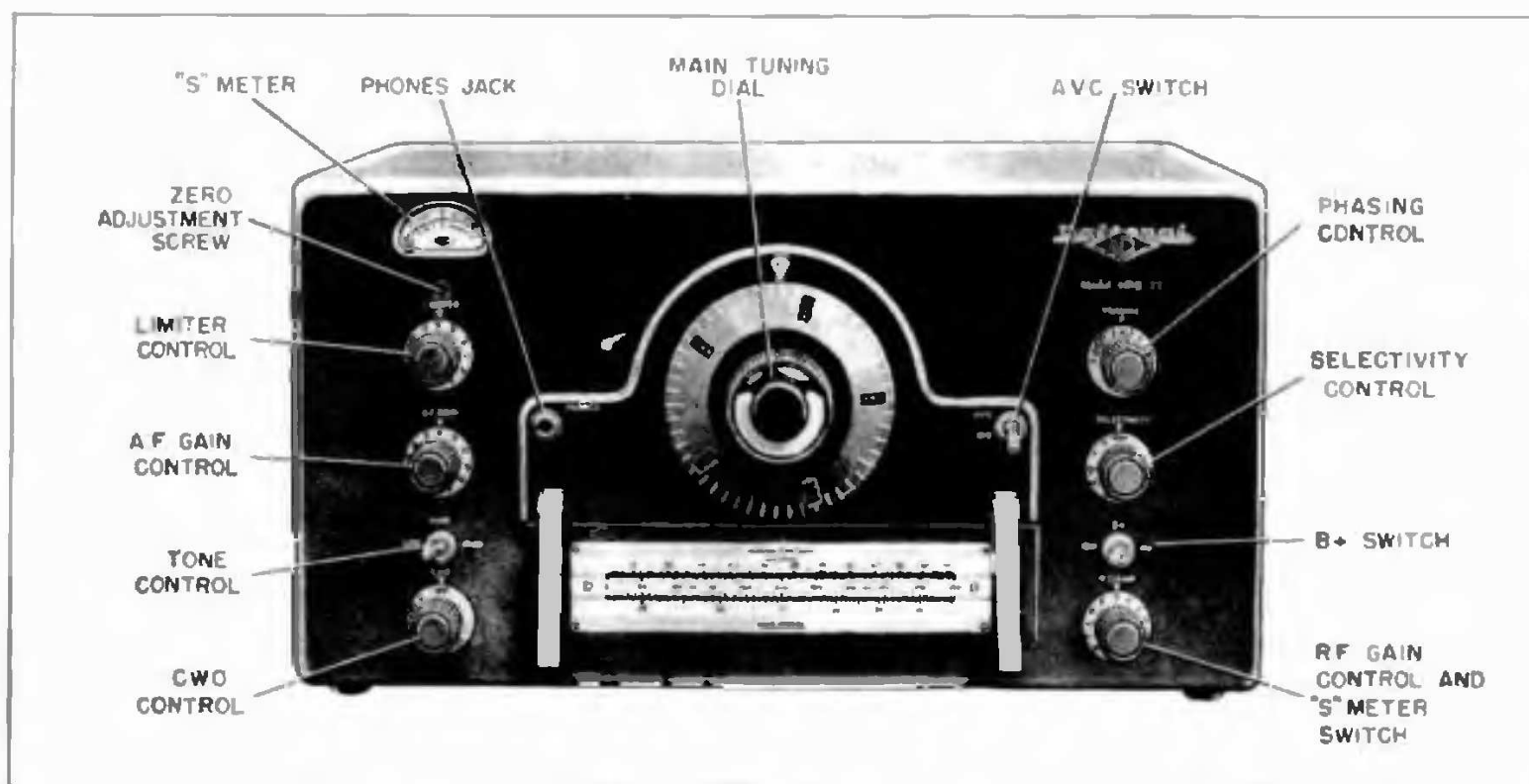

Figure No. 4. Front View of Receiver

the crystal bridge circuit and eliminate interfering signals or heterodynes.

The C.W.O. switch and vernier tuning adjustments control the action of the C.W. Oscillator transformer. The C.W. Oscillator is used to produce an audible beat note when receiving C.W. signals or to locate the carrier of a weak M.C.W. station. Rotating the C.W.O. knob in a clockwise direction from OFF removes the ground from the cathode of the C.W. Oscillator, thus permitting it to oscillate. Further rotation of the knob from 0 on the scale to 10 varies the frequency of oscillation over a range of approximately 3 kilocycles. The C.W. Oscillator tunes to the Receiver intermediate frequency at 9 on the graduated scale.

The A.V.C. switch is a two-position toggle marked A.V.C. -OFF. The automatic volume control circuits are operative with the toggle switch in the A.V.C. or upper position.

The A.F. GAIN control adjusts the volume level of the signal at both phone jack and loud-speaker terminals. Clockwise rotation of this control increases the signal applied to the grid of the first audio amplifier tube.

The LIMITER control serves to switch on the limiter, and following this, to adjust the threshold at which limiting action

starts. With the LIMITER control turned on (at position 0 on the dial scale) limiting action automatically takes place at a relatively high percentage modulation. Rotating the control clockwise progressively lowers the threshold, or percentage modulation, at which limiting action starts until maximum clipping is achieved at 10. This limiter is double-action in that limiting is accomplished by suppression of both positive and negative peaks.

The S-METER for indicating carrier intensity or signal strength is turned on by rotating the R.F. GAIN control to 10. At this setting the S-Meter switch on back of the control is closed connecting the S-Meter into the circuit.

The TONE control is a two-position switch serving to select the desired audio output frequency characteristic. The "Low" position attenuates the higher audio frequencies while the "High" position provides an audio output response equivalent to normal Receiver reproduction.

The BANDSPREAD switch for each of the four bandspread coil sets is located on each coil set. Inspection of the coil set terminal panels will show several small rectangular metal pieces. There are two of these metal pieces or terminal blocks on each coil which are tapped and countersunk for a flat-head machine screw. With the

screws in the left-hand position, the coil range will be that shown on the top scale of the calibration chart. It is only necessary to move each of the four screws to the right-hand terminal block of each coil to change the calibration from General Coverage to bandspread as shown on the bottom scale of the calibration chart. See Figure No. 6.

### 3-2. Phone Reception

After the HRO-7 is properly installed as outlined in Section 2, it is placed in operation by the following adjustments:

1. Set the Power Unit switch at ON.
  2. Set the Receiver B+ switch at ON.
- It is recommended that the operator allow approximately one minute warm-up time before the B+ switch is turned ON. This delay is necessary to permit the Voltage Regulator tube to function efficiently directly after the B+ switch is turned ON.
3. Turn the R.F. GAIN control to 10.
  4. Set the A.V.C. switch at A.V.C.
  5. Turn the C.W.O. control to the OFF position.
  6. Turn the SELECTIVITY control to OFF.
  7. Turn the PHASING control to 0.
  8. Turn the LIMITER control to OFF.
  9. Set the TONE control at the position giving the desired audio output tone.
  10. Turn the A.F. GAIN control to the position giving the desired audio volume.

The Receiver is now adjusted for the reception of phone signals and will tune to the frequency corresponding to the plug-in coil set in use and the setting of the MAIN TUNING dial. The position of the four screws on the coil set in use, as previously mentioned in paragraph 1 of this section, will determine the frequency coverage, i.e., General Coverage or Bandspread.

The settings given above are of necessity for reception of signals of average strength. Exceptionally strong or weak signals may require modification of

the above settings. Very strong signals may cause overload or distortion in the Receiver with the R.F. GAIN control at 10. In this case retarding this control slightly until the overload or distortion disappears is recommended. Audio output should be controlled entirely by means of the A.F. GAIN control. Very weak signals are best received with the R.F. GAIN control fully advanced. If the level of background noise in the Receiver proves objectionable, such as might be the case when receiving local broadcast stations, the R.F. GAIN control may be retarded to reduce the high level of noise as desired. However, when operating with the R.F. GAIN control well retarded, the full range of A.V.C. action will not be realized.

Operating the Receiver with A.V.C. off will result in an increase in sensitivity in some cases, depending on the incoming signal. With A.V.C. off, however, greater care should be taken in the setting of the A.F. and R.F. GAIN controls. Generally, the A.F. GAIN control can be advanced to some point near 10 and the R.F. GAIN control used to adjust the audio output volume. Overload, as indicated by excessive distortion, will result if the R.F. GAIN control is advanced too far.

Various types of interference which may be encountered due to adverse receiving conditions can be minimized by utilization of the following controls in the manner described:

**NOISE LIMITER** -- When a signal is accompanied by static peaks or noise pulses of high intensity and short duration, the best signal-to-noise ratio will be obtained by turning ON the LIMITER control. In general, it will be found that turning the LIMITER control ON, to 0 on the dial scale, will effectively minimize interference caused by external noise pulses. In cases where the noise pulses are extremely pronounced a higher degree of noise suppression will be realized by advancing the LIMITER control to a higher dial setting.

**TONE CONTROL** -- An improvement in signal-to-noise ratio can be realized, when receiving weak signals through interference, by setting the TONE control at

LOW.

SELECTIVITY and PHASING -- For M.C.W. reception the normal setting of the SELECTIVITY control is at one of the positions affording broad selectivity. Positions 1 and 2 are recommended. Selectivity may be progressively increased by turning the SELECTIVITY control to positions 3, 4 and 5 although too sharp selectivity for M.C.W. reception will render phone signals unintelligible due to excessive side-band cutting. The PHASING control is used to attenuate, or eliminate, if possible, interfering signals. The PHASING control is normally set at 0 on the scale for reception of M.C.W. signals. If, after tuning in a signal, an interfering signal causes a heterodyne or whistle, the PHASING control should be adjusted until the interfering signal is reduced to a minimum. The setting of the PHASING control which gives maximum attenuation of the heterodyne will depend on the pitch of the heterodyne whistle. If the beat-note is above 1,000 cycles, the optimum PHASING control setting will be zero; if the beat-note is 300 or 400 cycles, the optimum PHASING control setting will be near one end of the scale or the other, depending upon whether the interfering signal is higher or lower in frequency than the desired signal.

### **3-3. C.W. Reception**

The initial adjustment of the Receiver controls for C.W. reception is the same as given in Section 3-2 except for the following:

1. Turn the C.W.O. control to ON.
2. Set the A.V.C. switch at OFF.

It is important that the A.V.C. switch is turned OFF for C.W. operation since the Receiver will block and become extremely insensitive if this is not done.

For the reception of C.W. signals the action of the crystal filter is similar to that for M.C.W. reception except that full use of the sharp selectivity position may be used without the loss of intelligibility experienced in M.C.W. reception. When maximum selectivity is used, (SELECTIVITY control at position 5), care must be exercised since the tuning is very critical. When the Receiver is slowly tuned across

the carrier of a received signal, the beat-note produced will be very sharply peaked in output at a particular audio pitch. This peak in response indicates the correct Receiver dial setting. The setting of the C.W.O. control must be such that the beat-note peak is well within the audible range so that the receiver peak response may be readily observed. A C.W.O. dial setting near 7 is recommended. After the Receiver has been correctly tuned, the pitch of the beat-note peak may be adjusted by means of the C.W.O. control to provide an audio tone which is pleasing to copy, or coincides with any response peaks in the speaker or headphones. Under these conditions, the Receiver will exhibit pronounced single-signal properties which may be demonstrated by tuning the Receiver to the other side of "zero-beat" so that the pitch is the same as before and observe the marked reduction in output. This dial setting is not recommended for use other than to demonstrate the single-signal properties of the Receiver. With the Receiver tuned to "crystal peak", an interfering signal may be attenuated by proper setting of the PHASING control since this control has little effect on the desired signal.

Similar to phone reception the LIMITER control can be used to great advantage in C.W. reception for the reduction of interference due to external noise pulses. For C.W. reception, however, the LIMITER control may be set at a well advanced position on the dial scale as excessive clipping of the modulation peaks will not be experienced as might be the case in phone reception.

### **3-4. Measurement of Signal Strength**

To measure the strength or intensity of a signal, the R.F. GAIN control must be advanced to 10, the A.V.C. switch set at ON and the C.W.O. control turned OFF. The crystal filter should be turned OFF by means of the SELECTIVITY control, and the PHASING control set at 0. The LIMITER, TONE and A.F. GAIN controls do not affect the S-Meter reading.

Tuning the Receiver to a signal will cause the meter to read, indicating the signal input in S-units or in decibels above the S-9 level.

With no R.F. input to the Receiver, or with the antenna disconnected, the S-Meter should read 0, plus or minus 1 S-unit. If it does not, the S-Meter circuit requires

adjustment. See Section 5.

Measurement of the signal strength of C.W. signals cannot be made with the C.W. oscillator in operation.

**SECTION 4. ALIGNMENT DATA**

**4-1. General**

Should realignment of the HRO-7 Radio Receiver become necessary the following alignment data should be carefully studied before making any circuit adjustments. It is important that the function of each circuit element is understood so that correct alignment may be obtained quickly and accurately. Adjustments referred to by number are shown in Figures 5, 6 and 8.

The complete alignment of the Receiver may be divided into three steps:

- (a) Intermediate Frequency Amplifier alignment including crystal filter adjustments.
- (b) General Coverage Alignment.
- (c) Bandsread Alignment.

**4-2. I.F. Amplifier Alignment**

The making of any adjustment indis-

criminatedly is cautioned against and no circuit should be realigned unless tests definitely indicate that rrealignment is necessary.

The Alignment of the Intermediate Frequency Amplifier may be easily checked in the following manner. The Receiver should be adjusted for normal operation with no antenna, A.V.C. OFF, R.F. GAIN at 9, Crystal Filter SELECTIVITY switch at 5, PHASING control at 0, and C.W.O. turned ON. The setting of the A.F. GAIN control does not affect the measurement and may be adjusted to provide sufficient output to make the required observations. The C.W.O. control should then be turned until a point is found where the predominant pitch of the background noise is lowest and a crystal ring is heard. This setting of the C.W.O. control should occur near 9 on the C.W.O. scale and the exact setting should be noted. The crystal filter should

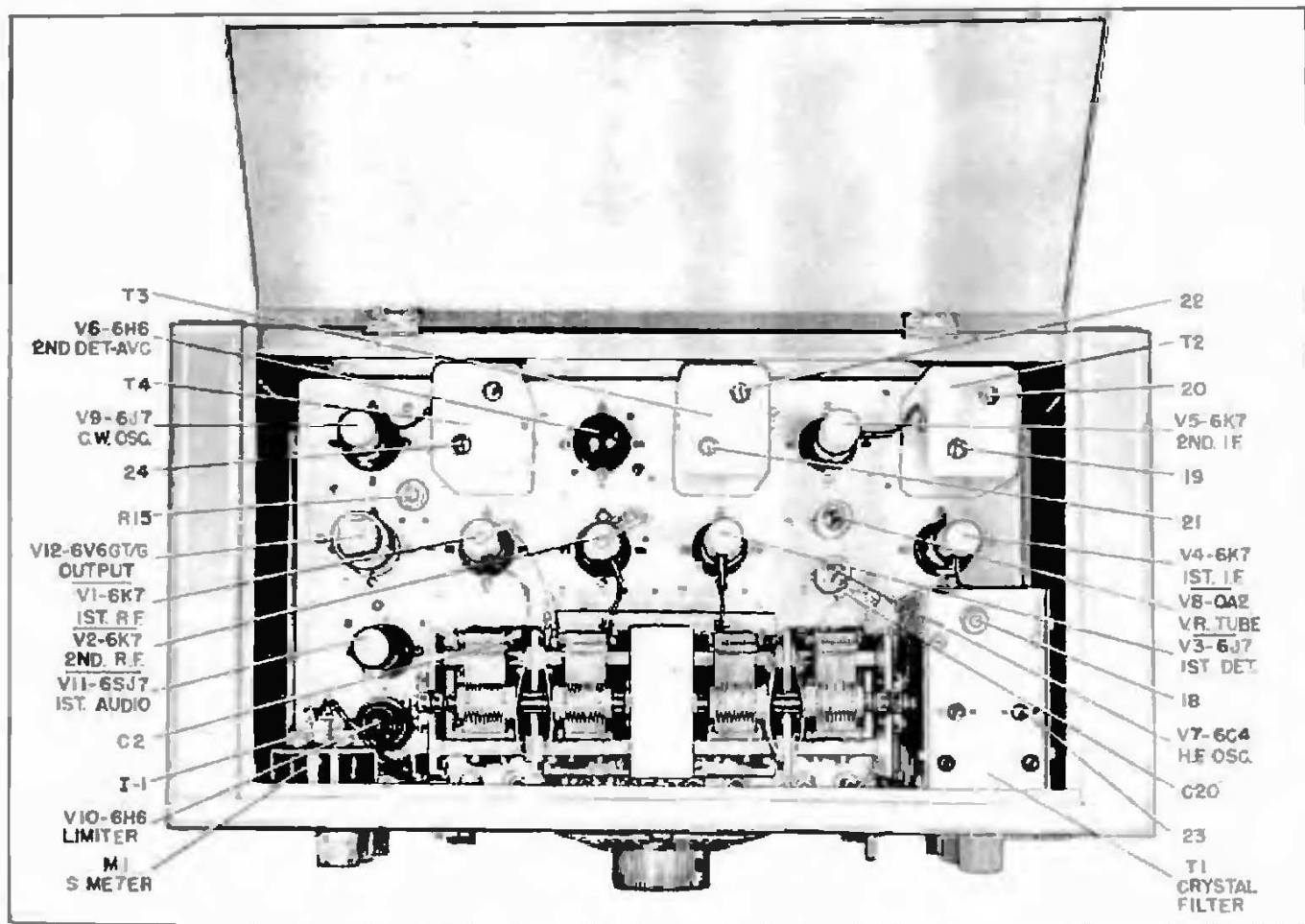

Figure No. 5. Top View of Receiver

then be disconnected from the circuit by turning the SELECTIVITY control to the OFF position. The C.W.O. control should again be adjusted for the lowest predominant pitch of background noise and this new setting noted. If the I.F. Amplifier alignment is correct, the setting of the C.W.O. control should be the same for both tests outlined above. The I.F. Amplifier should not be realigned, however, unless the test shows appreciable misalignment.

The intermediate frequency of the HRO-7 is 456 kilocycles, plus or minus 2 kilocycles. The exact frequency is determined by the quartz crystal resonator in the crystal filter.

Trimmer capacitors are provided on the crystal filter and on each I.F. transformer. These capacitors are numbered 17, 18, 19, 20, 21, 22, 23 on Figure Nos. 5 and 6.

The high output lead of an accurately calibrated signal generator should be connected to the grid terminal of the first detector tube and the ground lead to any convenient point on the chassis. The flexible lead need not be disconnected from the grid of the tube. A dummy antenna is not used. The C.W.O. should be turned on and the modulation of the signal generator turned off to provide a steady C.W. test signal. Set the PHASING control at 0, the SELECTIVITY control at 5, and the A.F. GAIN control at maximum or fully advanced. An output meter with a 5000 ohm resistive load should be connected to the output of the Receiver. Output terminals are available at two convenient locations: the two input terminals on the output transformer mounted on the MCR and RFSH Loudspeakers or the five prong output socket, X-1, at the rear of the Receiver. If the output socket on the Receiver is used for connection of an output meter a five prong plug, wired in the same manner as the loudspeaker plug shown on the Schematic Diagram, may be used for convenience in connecting the output meter to the Receiver.

The signal generator should be tuned to approximately 456 kilocycles and its output adjusted to give a convenient reading on the output meter. Tune the signal generator to the frequency producing maximum reading on the output meter; a definite

sharply peaked response will be noted. The signal generator output should be reduced now in order to avoid I.F. or audio overload and the C.W.O. should be adjusted to give an audio beat-note at some frequency between 400 and 1000 cycles per second.

The I.F. amplifier trimmer capacitors, numbers 17, 19, 20, 21 and 22, should be carefully tuned to produce a maximum reading on the output meter. The order of adjustment is not important. While tuning the I.F. amplifier trimmer capacitors it will be necessary to reduce the signal generator output if the I.F. amplifier gain increases to the overload point.

The crystal filter SELECTIVITY control should be set at 1 and the signal generator detuned between 3 and 4 kilocycles to one side of the crystal frequency, crystal filter trimmer capacitor Number 18 should be tuned for maximum output meter indication. After making this adjustment, the SELECTIVITY control should be set at off and the signal generator retuned to exact crystal frequency. Compensator trimmer capacitor Number 23 should then be tuned for maximum reading on the output meter.

After the I.F. amplifier has been aligned, the tuning of the C.W.O. should be checked. This may be readily accomplished by repeating the test previously described with the crystal filter off. If the setting of the C.W.O. control does not occur at or near 9, with this test, turn the C.W.O. control to 9 and carefully adjust trimmer Number 24 by ear for the lowest pitch of background noise.

#### **4-3. General Coverage Alignment**

The data given in this section applies to the General Coverage alignment of the H.F. oscillator and R.F. amplifier stages of coil sets A, B, C, D, E and F. The original alignment at National Laboratories is accomplished by the use of precision, crystal-controlled test oscillators. No realignment should be attempted unless a reliable test signal source is available. In the case of General Coverage H.F. oscillator alignment, a test signal source with an accuracy of 1% or better is required. For Bandsread alignment the cali-

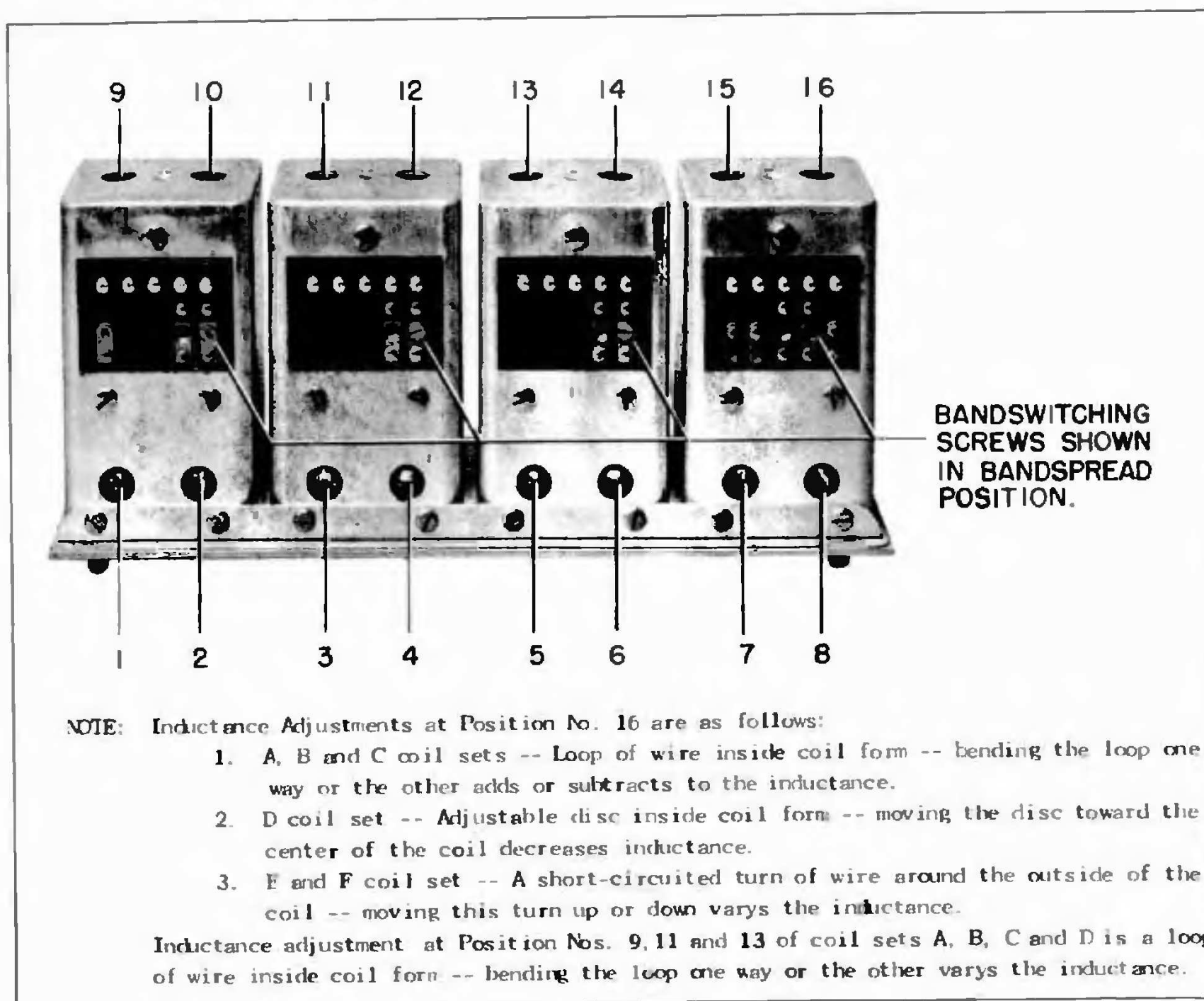

Figure No. 6. Typical Coil Set Showing Alignment Adjustment Locations

bration accuracy demands that the test signal source have the accuracy of precision-calibrated crystals. The entire range of test frequencies required may be obtained by the use of nine crystals operating at their fundamental and harmonic frequencies. The frequency of these crystals is as follows: 0.1, 1.0, 2.0, 3.5, 6.8, 7.0, 7.3, 14.4 and 15 megacycles.

The need for realignment of the H.F. oscillator of any band is indicated when the frequency calibration of the Receiver dial is in error by more than 2% at the high frequency end of the band in question. If it is determined that realignment is necessary, adjust the Receiver controls as follows: R.F. GAIN at 9, C.W.O. off, A.V.C. off, Selectivity off, Bandswitching screws in the General Coverage position and

the A.F. GAIN set to provide a suitable audio output level.

The following Alignment Chart gives the step-by-step procedure to follow in effecting the General Coverage alignment of each coil set. It is important that the chart of adjustments is adhered to in the order shown. It should be noted that General Coverage alignment affects Bandspread alignment, but that adjustment of Bandspread alignment does not affect General Coverage.

Particular care should be taken when adjusting trimmers shown at position Number 8, the H.F. oscillator trimmers. It is imperative that the high frequency oscillator is set to operate at a frequency above the R.F. amplifier frequency and not below. This can be checked by tuning in the image



General Coverage Alignment Chart					
Step	Coil Set	Adjust Signal Source To:	Set Dial At	Adjust To Receive Test Signal	Adjust For Maximum Output
✓1	A	30.0 Mc.	485	Trimmer at Pos. No. 8	Trimmer at Pos. Nos. 2,4,6.
✓2	A	14.4 Mc.	54	Inductance at Pos. No. 16	Inductance at Pos. Nos. 9,11,13.
✓3	A	30.0 Mc.	485		Check step 1. Repeat steps 1 and 2 if necessary.
✓1	B	14.4 Mc.	485	Trimmer at Pos. No. 8	Trimmer at Pos. Nos. 2,4,6.
✓2	B	7.0 Mc.	28	Inductance at Pos. No. 16	Inductance at Pos. Nos. 9,11,13.
✓3	B	14.4 Mc.	485		Check step 1. Repeat steps 1 and 2 if necessary.
✓1	C	7.3 Mc.	490	Trimmer at Pos. No. 8	Trimmer at Pos. Nos. 2,4,6.
2	C	3.5 Mc.	23	Inductance at Pos. No. 16	Inductance at Pos. Nos. 9,11,13
3	C	7.3 Mc.	490		Check step 1. Repeat Steps 1 and 2 if necessary.
1	D	4.0 Mc.	490	Trimmer at Pos. No. 8	Trimmer at Pos. Nos. 2,4,6.
2	D	1.8 Mc.	36	Inductance at Pos. No. 16	Inductance at Pos. Nos. 9,11,13.
3	D	4.0 Mc.	490		Check step 1. Repeat Steps 1 and 2 if necessary.
1	E	2.0 Mc.	470	Trimmer at Pos. No. 8	Trimmer at Pos. Nos. 2,4,6.
2	E	1.0 Mc.	68	Padder at Pos. No 7	
3	E	1.4 Mc.	245	Inductance at Pos. No. 16	
4	E	2.0 Mc.	470		Check Step 1. Repeat steps 1,2 and 3 if necessary.
1	F	0.9 Mc.	430	Trimmer at Pos. No. 8	Trimmer at Pos. Nos. 2,4,6.
2	F	0.5 Mc.	30	Padder at Pos. No. 7	
3	F	0.7 Mc.	230	Inductance at Pos. No. 16	
4	F	0.9 Mc.	430		Check Step 1. Repeat Steps 1,2 and 3 if necessary.

of the test signal, which should appear 912 kilocycles lower on the Receiver dial. If it is found that the image does not appear at this dial setting the H.F. oscillator is incorrectly adjusted and the trimmer capacity at position Number 8 must be decreased until the image and fundamental signals appear at the proper points on the dial. After the H.F. oscillator is correctly calibrated the R.F. amplifier trimmers at position Numbers 2, 4 and 6 should be adjusted for maximum receiver gain. It may be desirable to align the R.F. amplifier trimmers at position Numbers 2, 4 and 6 using Receiver background noise as an indication of maximum gain, rather than the signal source. If this alternate method of alignment is used the point of maximum gain is that setting of the trimmers, which provides the loudest Receiver background noise. However, it is possible to align the R.F. amplifier stages to the image frequency using background noise as an indicator. A check of this possibility is to tune in the image signal -- if the image is weaker than the fundamental signal the R.F. amplifier stages are correctly aligned.

Correction of tracking errors of the R.F. amplifier stages at the low frequency limit of each coil set is accomplished by the adjustments listed on the Alignment Chart. The actual tracking of these stages may be checked by pressing the outside rotor plates of the main tuning capacitor section toward or away from the stator in a manner assuring that the rotor plates will spring back to their original position. Any change in capacity should decrease the Receiver gain if the stage is tracking properly.

The locations of the adjustments referred to in this section and on the Alignment Chart are shown on Figure Number 6.

#### **4-4. Band-Spread Alignment**

The data given in this section applies to the Bandsread Alignment of the H.F. oscillator and R.F. amplifier stages of coil sets A, B, C and D. It is important that no Bandsread adjustments are made until after completion of General Coverage alignment, as General Coverage adjustments affect Bandsread alignment.

The need for realignment of the H.F.

oscillator of any band is indicated when the frequency calibration of the Receiver dial is in error by more than +20 divisions. To effect alignment the Receiver controls are adjusted the same as outlined in Section 4-3, except that the four Bandswitching screws must be in the right-hand positions.

The procedure in effecting Bandsread alignment is accomplished by adhering to the instructions given in the Bandsread Alignment Chart. The procedure is similar to that for General Coverage except for the method followed in checking tracking errors of the R.F. amplifier stages at the low frequency limit of each coil set. To secure an indication of proper tracking check the settings of trimmers at position Numbers 1, 3 and 5 for the position of maximum Receiver gain. Any change in capacity should decrease the Receiver gain indicating proper tracking. The use of trimmers 1, 3 and 5 for a tracking check may destroy their proper setting and this should be carefully checked at the high frequency limit of the coil set.

The locations of the adjustments referred to in this section and on the Alignment Chart are shown on Figure Number 6.

#### **4-5. First R.F. Stage Alignment with Low Impedance Transmission Line**

If a low impedance transmission line is to be used with the Receiver, it may be necessary to realign the first R.F. amplifier at the high end of each band. The general coverage adjustments affect the bandsread adjustments and should be performed first. The following procedure should be adhered to:

(a) General Coverage:

(1) With the four screws used for switching from General Coverage to Bandsread in the left-hand (General Coverage) position, adjust the Receiver for normal operation as follows: R.F. GAIN at 9, C.W.O. off; A.V.C. off, CRYSTAL FILTER off, A.F. GAIN set to provide a suitable signal.

(2) Connect the antenna feeders to the Receiver antenna terminals and tune the Receiver to the signal shown in step 1 on the General Coverage Alignment Chart for the coil set being aligned. Adjust trimmer

at position Number 2 on Figure Number 6 for maximum signal output. If no signal can be received, the trimmer should be adjusted for maximum background noise.

(b) Bandsread:

(1) With the Receiver adjusted the same as for general coverage, shift the four screws on the coil terminal panels to the right-hand position (bandsread position).

(2) Connect the antenna feeders to the Receiver antenna terminals and tune the Receiver to the signal shown in step 1 on the Bandsread Alignment Chart for the

coil set being aligned. Adjust trimmer at position Number 1 on Figure Number 6 for maximum signal output. If no signal can be received the trimmer should be adjusted for maximum background noise.

**4-6. S-Meter Adjustment**

The S-Meter balancing resistor R-15, is used to obtain zero meter reading in the absence of signal input to the Receiver. The adjustment is as follows: Set the R.F. GAIN control at 10, A.V.C. ON, and disconnect the antenna. R-15 should now be adjusted until the S-Meter reads zero.

Bandsread Alignment Chart					
NOTE: Do not effect Bandsread Alignment until after completion of General Coverage					
Step	Coil Set	Adjust Signal Source To:	Set Dial At	Adjust To Receive Test Signal	Adjust For Maximum Output
1	A	30.0 Mc.	450	Trimmer at Pos. No. 7	Trimmer at Pos. Nos. 1, 3, 5.
2	A	27.2 Mc.	61	Padder at Pos. No. 15	Padder at Pos. Nos. 10, 12, 14.
3	A	30.0 Mc.	450		Check Step 1. Repeat Steps 1 and 2 if necessary. Check Step 1.
1	B	14.4 Mc.	450	Trimmer at Pos. No. 7	Trimmer at Pos. Nos. 1, 3, 5.
2	B	14.0 Mc.	50	Padder at Pos. No. 15	Padder at Pos. Nos. 10, 12, 14.
3	B	14.4 Mc.	450		Check Step 1. Repeat Steps 1 and 2 if necessary. Check Step 1.
1	C	7.3 Mc.	450	Trimmer at Pos. No. 7	Trimmer at Pos. Nos. 1, 3, 5.
2	C	7.0 Mc.	50	Padder at Pos. No. 15	Padder at Pos. Nos. 10, 12, 14.
3	C	7.3 Mc.	450		Check Step 1. Repeat Steps 1 and 2 if necessary. Check Step 1.
1	D	4.0 Mc.	450	Trimmer at Pos. No. 7	Trimmer at Pos. Nos. 1, 3, 5.
2	D	3.5 Mc.	50	Padder at Pos. No. 15	Padder at Pos. Nos. 10, 12, 14.
3	D	4.0 Mc.	450		Check Step 1. Repeat Steps 1 and 2 if necessary. Check Step 1.

**SECTION 5. MAINTENANCE**

**5-1. General Maintenance Data**

Any repairs in the HRO-7 Receiver which necessitate resoldering of joints should be made with care. A good mechanical connection should be made before the solder is applied.

Failure of a vacuum tube in the receiver may reduce the sensitivity, produce intermittent operation, or cause the equipment to be completely inoperative. In such cases, all tubes should be checked either in an analyzer or similar tube testing equipment, or by replacement with tubes of proven quality. When any tube is tested, it should be tapped or jarred, to make sure that it has no internal loose connection or intermittent short circuit.

When tube replacements become necessary, substitution of new tubes may alter the alignment of the R.F. or I.F. circuits inasmuch as the replacement tubes may not be identical with those originally employed. The necessity for realignment as well as alignment procedure is discussed in

Section 4.

In case of breakdown or failure of the Receiver, the fault must first be localized. This can often be accomplished by observation of some peculiar action of one of the controls. Reference to the circuit diagram will aid in checking voltages at the various tube elements.

Bypass or filter capacitors which develop poor connections internally, or which become open-circuited, will cause decreased sensitivity, oscillation or poor stability. The defective unit can be located by temporarily connecting a good capacitor in parallel with each capacitor that is under suspicion.

Failure of any bypass or filter capacitor may seriously overload resistors in associated circuits. Overloads of sufficient magnitude to permanently damage a resistor will cause the surface of the resistor to be scorched, making the defective unit easy to locate by visual inspection.

Open or short-circuited resistors can be definitely located by measuring the re-

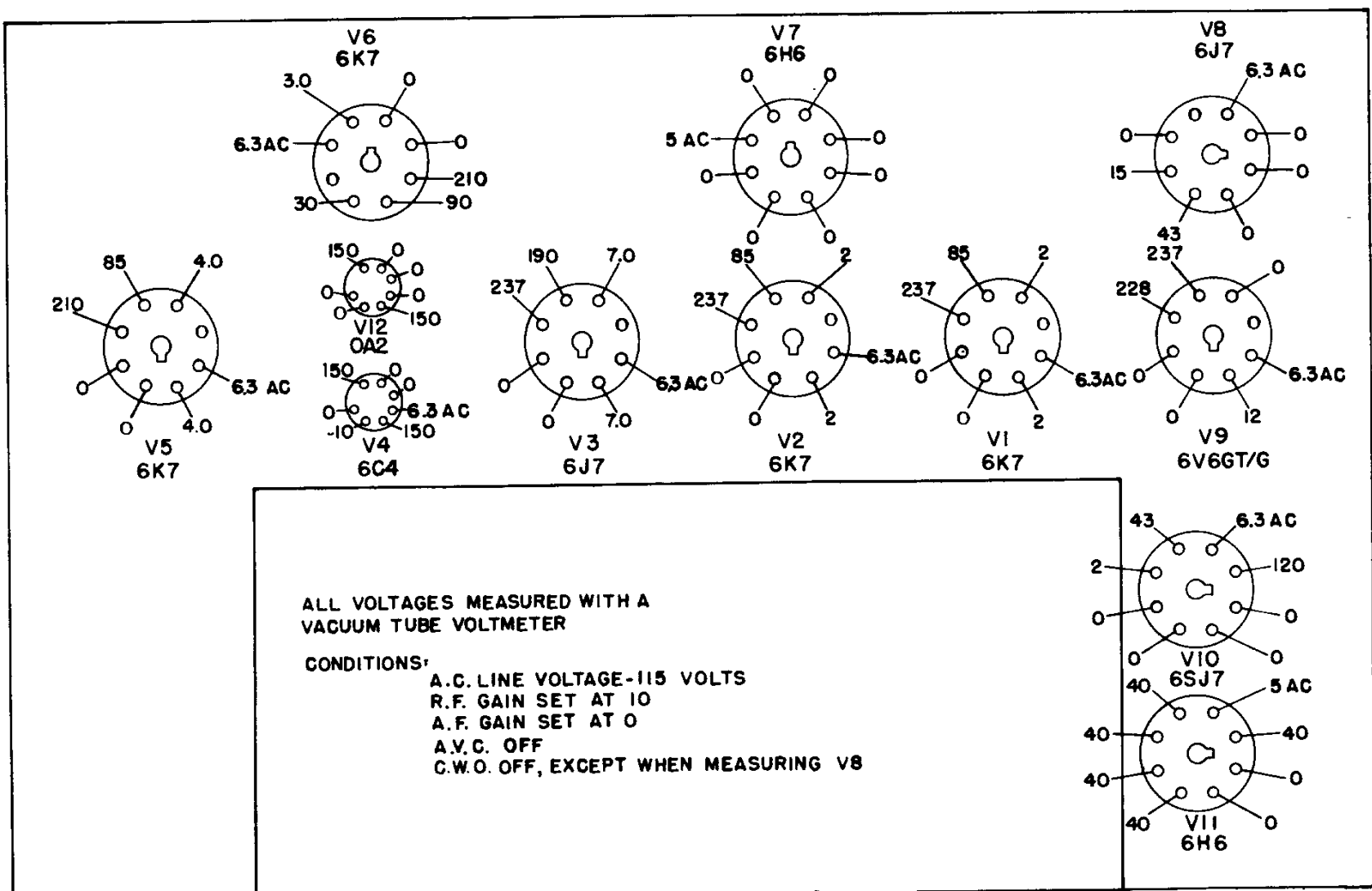

Figure No. 7. Tube Socket Voltages

sistance of each individual resistor. The wiring diagram should be consulted to make sure that any particular resistor under test is not connected in parallel with some other circuit element which might produce false measurement.

Loose connections which cause intermittent or noisy operation can often be found by tapping, or shaking, any component under suspicion, with the Receiver adjusted for normal operation.

### 5-2. Main Tuning Dial

The main tuning dial should normally give no trouble. If, however, the dial should become removed from the Receiver it should NOT be operated until mounted on the condenser shaft WITH SET-SCREWS TIGHT. This is because the dial is only designed to rotate for ten revolutions (0 to 500) and if turned farther than this the mechanism will be damaged. When mounted on the condenser, limit stops protect the dial provided the assembly is properly done. The procedure for re-mounting the dial is as follows:

(a) Place dial on condenser shaft, tighten set-screws and turn dial counter-clockwise to fully mesh condenser rotor plates so that the tips of the rotor plates are flush with the edge of the stator plates.

(b) Loosen set-screws and rotate dial slowly until dial reading has decreased to zero.

(c) Tighten the set-screws.

(d) Check position of rotor plates at zero. The tips of the rotor plates should be flush with the edge of the stator plates at zero. A slight adjustment may be necessary and this is done by loosening the set-screws, adjusting the position of the dial and tightening the set-screws again.

If it is necessary to remove the dial at any future time, turn to 250 before re-

moving the dial, and do not disturb the setting of either the dial or condenser until reassembled. If in doubt about the correct position, inspect the springs on the back of the dial. When the dial reads 250 these springs should be straight-up-and-down, they must not be tipped to one side.

It is important that the backplate and dial do not become separated.

The backplate is held in place by two springs so that its gear teeth mesh with the dial gear teeth in correct relationship for proper dial operation. If this backplate should be sprung out of place, it may return to an incorrect position and the proper dial numbers will not appear in the windows when the dial is used. To ascertain that the two parts are in correct position, proceed as follows:

(a) Locate small window near outer periphery of dial backplate and also locate dial number window on face of dial which is 180° removed from the small backplate window.

(b) Hold dial so backplate lies flat in palm of left-hand and with right hand rotate dial knob until 250 appears in previously located dial window.

(c) If dial is properly adjusted it will be noted that the pointer at the outer edge of the small window lines up with a marked tooth on the dial itself. It will be found that the dial and backplate can be moved so that the backplate pointer will mesh between teeth at points equidistant from marked tooth in either direction.

(d) If by checking as in paragraph (c), the dial is found not properly adjusted, it will be necessary to separate the backplate from the dial far enough to bring the two gears out of mesh and then re-mesh the two parts until the proper setting is found. A number of trials may be required before the correct mesh is found.

## SECTION 6. POWER UNITS

### 6-1. Type 697 Power Unit

The National Type 697 Table Model Power Unit operates from 115 or 230 volts A.C., 50 or 60 cycles, to provide 240 volts

at 85 milliamperes D.C. and 6.2 volts at 3.3 amperes A.C. The circuit diagram of this unit is shown in Figure 9. Output voltages for both A and B supply are available at a four prong socket for convenient

connection of the Receiver power plug. Section 6-3 shows typical operating voltages and currents when used with the HRO-7 Radio Receiver. The Type 697 Power Unit consists of a power transformer, glass Type 5Y3GT/G rectifier tube, and a single section condenser-input filter. B- is connected to the Power Unit Chassis. The Power Unit for rack mounting is designated as SPU-697.

**6-2. Type 686S Power Unit**

The National Type 686S Table Model Power Unit operates from a 6 volt D.C. supply to provide approximately 165 volts at 55 milliamperes D.C. Battery clips are provided for convenient connection to a 6 volt storage battery or similar source of power. Output voltages for both A and B supply are available at a four prong socket for convenient connection of the Receiver power plug. Figure 10 shows the schematic wiring diagram. Section 6-3 shows typical operating voltages and currents when used with the HRO-7 Radio Receiver. The 686S Power Unit consists of a vibrapack and a single section condenser-input filter.

The vibrapack uses a 6X5 (or OZ4) type rectifier tube and a vibrator. It should be noted that B- is not connected to the Power Unit chassis; A- is connected to the chassis. The National Type SPU-686S Power Unit is the rack-mounted model.

**6-3. Typical Operating Conditions for Power Units**

The following table shows typical operating currents and voltages of the 697, 686S Power Units when used with HRO-7 Receivers:

VARIABLE	697	686S
Primary Voltage	115 or 230 VAC	6V DC
Frequency	50/60 cps	0
Heater Voltage	6.2 VAC	6V DC
Heater Current	3.3 Amp. AC	3 Amp.
B Voltage	240 VDC	165V DC
B Milliamperes	85 DC	55 DC
Line Current	.65 or .32 Amp.	6.5 Amp.
Power Consumption	74 Watts	39 Watts

**PARTS LIST**

**SECTION 7**

Sym.	Function	Type	Rating
<b>CAPACITORS</b>			
C-1	Main Tuning	Air	4-section variable
C-1A	First R.F. Tuning	Air	225 mmf., max.
C-1B	Second R.F. Tuning	Air	225 mmf., max.
C-1C	First Det. Tuning	Air	225 mmf., max.
C-1D	H.F. Oscillator Tuning	Air	225 mmf., max.
C-2	First R.F. Grid Filter	Paper	.01 mfd., 600 VDCW
C-3	First R.F. Cathode Bypass	Paper	.1 mfd., 400 VDCW
C-4	V-1, V-2, V-4 & V-5 Screen Bypass	Paper	.1 mfd., 400 VDCW
C-5	First R.F. Plate Filter	Paper	.1 mfd., 600 VDCW
C-6	Second R.F. Grid Filter	Paper	.01 mfd., 600 VDCW
C-7	Second R.F. Cathode Bypass	Paper	.1 mfd., 400 VDCW
C-8	Second R.F. Plate Bypass	Paper	.1 mfd., 600 VDCW
C-9	First Detector Cathode Bypass	Paper	.1 mfd., 400 VDCW
C-10	Crystal Filter Bridge	Ceramic	47 mmf., 500 VDCW
C-11	Crystal Filter Bridge	Ceramic	62 mmf., 500 VDCW
C-12	First I.F. Grid Filter	Paper	.01 mfd., 600 VDCW
C-13	First I.F. Cathode Bypass	Paper	.1 mfd., 400 VDCW
C-14	Second I.F. Grid Filter	Paper	.01 mfd., 600 VDCW

## SECTION 7

## PARTS LIST (Continued)

Symbol	Function	Type	Rating
<b>CAPACITORS (Continued)</b>			
C-15	Second I.F. Cathode Bypass	Paper	.1 mfd., 400 VDCW
C-16	Second Detector Load	Ceramic	270 mmf., 500 VDCW
C-17	T-3 to A.V.C. Rectifier Coupling	Ceramic	100 mmf., 500 VDCW
C-18	V-9 to V-6 Coupling	Ceramic	3 mmf., 500 VDCW
C-19	First and Second I.F. Plate Filter	Paper	.25 mfd., 600 VDCW
C-20	H.F. Oscillator Temp. Compensating (minus .00077 mmf./mmf./°C)	Ceramic	10 mmf., 500 VDCW
C-21	H.F. Oscillator Grid Coupling	Ceramic	100 mmf., 500 VDCW
C-22	V-7 to V-3 Coupling	Paper	.01 mfd., 600 VDCW
C-23	H.F. Oscillator Plate Bypass	Paper	.1 mfd., 400 VDCW
C-24	C.W. Oscillator Grid Coupling	Mica	.001 mfd., 500 VDCW
C-25	C.W. Oscillator Tuning	Air	30 mmf.
C-26	C.W. Oscillator Screen Bypass	Paper	.01 mfd., 600 VDCW
C-27	V-6 to V-10 Coupling	Paper	.1 mfd., 400 VDCW
C-28	Limiter Plate Filter	Paper	.1 mfd., 400 VDCW
C-29	Limiter Threshold Filter	Paper	.1 mfd., 400 VDCW
C-30	V-10 to V-11 Coupling	Paper	.01 mfd., 600 VDCW
C-31	First Audio Cathode Bypass	Elec.	25 mfd., 50 VDCW
C-32	First Audio Screen Bypass	Paper	.1 mfd., 400 VDCW
C-33	First Audio Plate Filter	Paper	.1 mfd., 400 VDCW
C-34	V-11 to V-12 Coupling	Paper	.1 mfd., 400 VDCW
C-35	Tone	Mica	.003 mfd., 600 VDCW
C-36	Audio Output Grid Bypass	Ceramic	160 mmf., 500 VDCW
C-37	Audio Output Cathode Bypass	Elec.	10 mfd., 50 VDCW
C-38	Audio Output Screen Bypass	Paper	.01 mfd., 600 VDCW
C-39	First R.F. Gen. Cov. Padder A Band	Mica	1200 mmf., 500 VDCW
C-40	A Band, First R.F. Bandsread Padder	Ceramic	12 mmf., 500 VDCW
	B Band, First R.F. Bandsread Padder	Ceramic	5 mmf., 500 VDCW
	C Band, First R.F. Bandsread Padder	Ceramic	12 mmf., 500 VDCW
	D Band, First R.F. Bandsread Padder	Ceramic	25.7 mmf., 500 VDCW
C-41	A Band, Antenna Coupling	Ceramic	40 mmf., 500 VDCW
C-42	A Band, Second R.F. Bandsread Padder	Ceramic	21 mmf., 500 VDCW
	B Band, Second R.F. Bandsread Padder	Ceramic	5 mmf., 500 VDCW
	C Band, Second R.F. Bandsread Padder	Ceramic	12 mmf., 500 VDCW
	D Band, Second R.F. Bandsread Padder	Ceramic	25.7 mmf., 500 VDCW
C-43	A Band, First Detector Bandsread Padder	Ceramic	21 mmf., 500 VDCW
	B Band, First Detector Bandsread Padder	Ceramic	5 mmf., 500 VDCW
	C Band, First Detector Bandsread Padder	Ceramic	12 mmf., 500 VDCW
	D Band, First Detector Bandsread Padder	Ceramic	25.7 mmf., 500 VDCW
C-44	A Band, H.F. Osc. Gen. Cov. Padder	Mica	.001 mfd., 500 VDCW
	B Band, H.F. Osc. Gen. Cov. Padder	Mica	2600 mmf., 500 VDCW
	C Band, H.F. Osc. Gen. Cov. Padder	Mica	1600 mmf., 500 VDCW
	D Band, H.F. Osc. Gen. Cov. Padder	Mica	900 mmf., 500 VDCW
	E Band, H.F. Osc. Gen. Cov. Padder	Mica	510 mmf., 500 VDCW
	F Band, H.F. Osc. Gen. Cov. Padder	Ceramic	350 mmf., 500 VDCW
C-45	A Band, H.F. Osc. Bandsread Trimmer	Ceramic	10 mmf., 500 VDCW
	B Band, H.F. Osc. Bandsread Trimmer	Ceramic	10 mmf., 500 VDCW
	C Band, H.F. Osc. Bandsread Trimmer	Ceramic	10 mmf., 500 VDCW
C-46	B Band, H.F. Osc. Gen. Cov. Trimmer	Ceramic	10 mmf., 500 VDCW
	C Band, H.F. Osc. Gen. Cov. Trimmer	Ceramic	10 mmf., 500 VDCW
C-47	C.W. Oscillator Trimmer	Ceramic	100 mmf., 500 VDCW
C-48	AVC Filter	Mica	0.01 mfd., 500 VDCW ✓

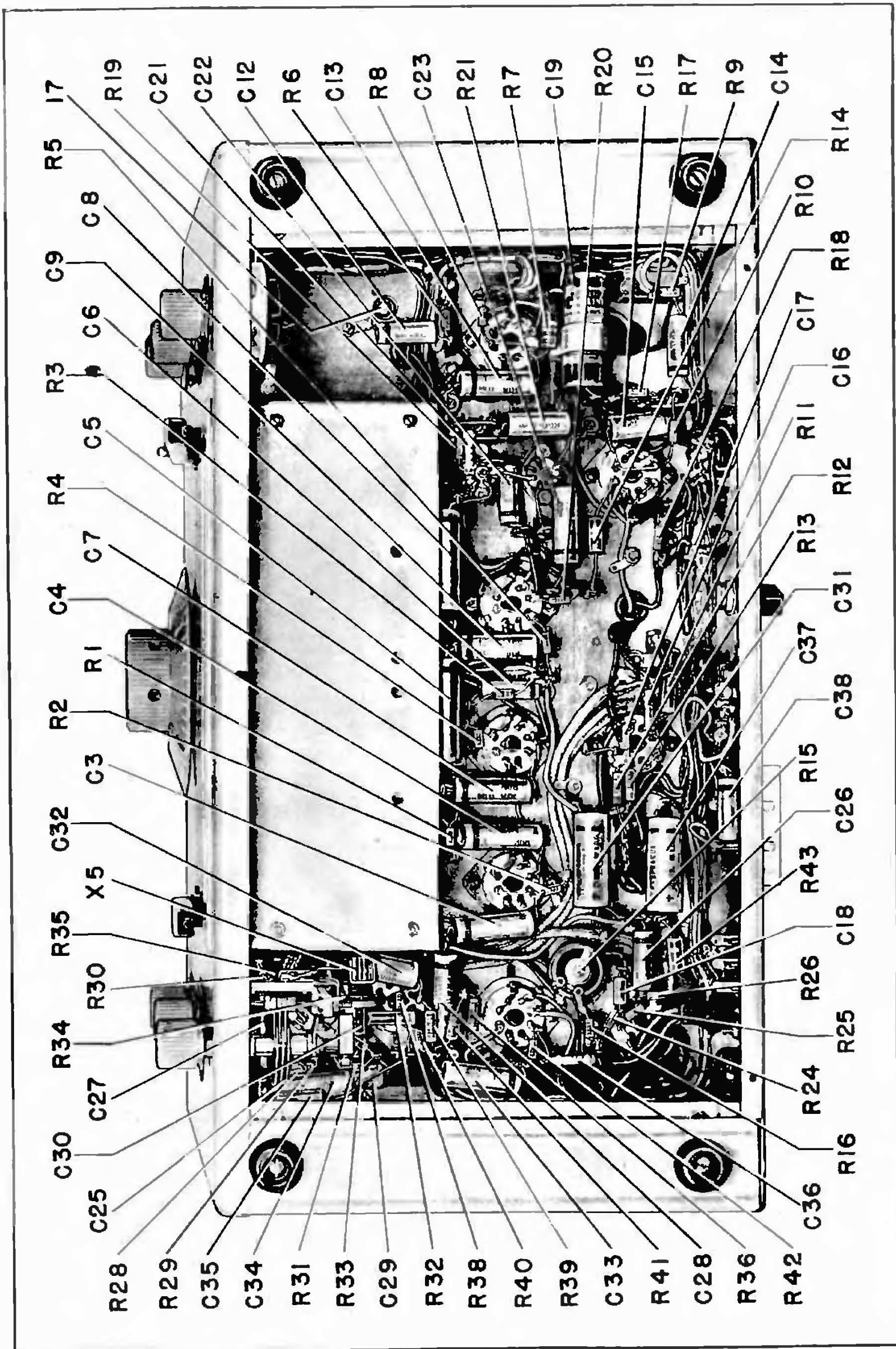

Figure No. 8. Bottom View of Receiver



## SECTION 7

## PARTS LIST (Continued)

Symbol	Function	Type	Rating
<b>RESISTORS</b>			
R-1	First R.F. Grid Filter	Fixed	470,000 Ohms, 1/2 W.
R-2	First R.F. Cathode	Fixed	330 Ohms, 1/2 W.
R-3	Second R.F. Grid Filter	Fixed	470,000 Ohms, 1/2 W.
R-4	Second R.F. Cathode	Fixed	330 Ohms, 1/2 W.
R-5	First Detector Cathode	Fixed	4,700 Ohms, 1/2 W.
R-6	First R.F. Grid Filter	Fixed	470,000 Ohms, 1/2 W.
R-7	V-1, V-2, V-4 & V-5 Screen Bleeder	Fixed	27,000 Ohms, 2 W.
R-8	First I.F. Cathode	Fixed	330/1,000 Ohms, 1/2 W.
R-9	Second I.F. Grid Filter	Fixed	470,000 Ohms, 1/2 W.
R-10	Second I.F. Cathode	Fixed	330 Ohms, 1/2 W.
R-11	V-6, Filament Dropping	Fixed	4.3 Ohms, 1 W.
R-12	A.V.C. Plate Load	Fixed	1,500,000 Ohms, 1/2 W.
R-13	A.V.C. Filter	Fixed	1,500,000 Ohms, 1/2 W.
R-14	V-1, V-2, V-4 & V-5 Screen Filter	Fixed	15,000 Ohms, 2 W.
R-15	S-Meter, zero adjusting	W.W. Var.	1,000 Ohms, 1 W.
R-16	S-Meter Bridge	Fixed	1,800 Ohms, 1/2 W.
R-17	S-Meter Shunt	Fixed	270 Ohms, 1/2 W.
R-18	S-Meter Bridge	Fixed	2,200 Ohms, 1/2 W.
R-19	H.F. Oscillator Grid	Fixed	22,000 Ohms, 1/2 W.
R-20	First Detector Screen	Fixed	100,000 Ohms, 1/2 W.
R-21	V-8 Dropping	Fixed	5,000 Ohms, 5 W.
R-22	R.F. Gain Control	W.W. Var.	10,000 Ohms, 1.5 W.
R-23	C.W. Oscillator Grid	Fixed	47,000 Ohms, 1/2 W.
R-24	C.W. Oscillator Plate	Fixed	220,000 Ohms, 1/2 W.
R-25	C.W. Oscillator Screen Filter	Fixed	100,000 Ohms, 1/2 W.
R-26	C.W. Oscillator Screen Bleeder	Fixed	100,000 Ohms, 1/2 W.
R-27	Limiter Threshold Control	Comp. Var.	500,000 Ohms, 1 W.
R-28	Second Detector Load	Fixed	22,000 Ohms, 1/2 W.
R-29	Second Detector Load	Fixed	470,000 Ohms, 1/2 W.
R-30	Limiter Plate	Fixed	220,000 Ohms, 1/2 W.
R-31	Limiter Threshold Filter	Fixed	220,000 Ohms, 1/2 W.
R-32	Limiter Filament Dropping	Fixed	4.3 Ohms, 1 W.
R-33	Limiter Cathode	Fixed	220,000 Ohms, 1/2 W.
R-34	Limiter Output Divider	Fixed	220,000 Ohms, 1/2 W.
R-35	Limiter Plate Load	Fixed	470,000 Ohms, 1/2 W.
R-36	Limiter Plate Filter	Fixed	820,000 Ohms, 1/2 W.
R-37	Audio Gain Control	Comp. Var.	500,000 Ohms, 1 W.
R-38	First Audio Cathode	Fixed	2,200 Ohms, 1/2 W.
R-39	First Audio Screen	Fixed	820,000 Ohms, 1/2 W.
R-40	First Audio Plate	Fixed	100,000 Ohms, 1/2 W.
R-41	First Audio Plate Filter	Fixed	47,000 Ohms, 1/2 W.
R-42	Audio Output Grid	Fixed	470,000 Ohms, 1/2 W.
R-43	Audio Output Cathode	Fixed	330 Ohms, 2 W.
<b>MISCELLANEOUS</b>			
I-1	S-Meter Lamp		6-8 V., 0.15 Amp.
J-1	Phones Jack	Multi-Okt.	
M-1	S-Meter	S Scale	0-1 M.A. D.C.
P-1	Power Cable and Plug		

## PARTS LIST (Continued)

## SECTION 7

Symbol	Function	Type	Rating
<b>MISCELLANEOUS (Continued)</b>			
S-1	Output Socket	Five-Prong	
S-2	Accessory Connector Socket	Octal	
T-1	First I.F. Transformer	Crys. Fil.	456 Kc.
T-2	Second I.F. Transformer	Air Tuned	456 Kc.
T-3	Second Detector Transformer	Air Tuned	456 Kc.
T-4	C.W. Oscillator Transformer	Air Tuned	456 Kc.
V-1	First R.F. Amplifier	6K7	
V-2	Second R.F. Amplifier	6K7	
V-3	First Detector	6J7	
V-4	First I.F. Amplifier	6K7	
V-5	Second I.F. Amplifier	6K7	
V-6	Second Detector, A.V.C.	6H6	
V-7	High Frequency Oscillator	6C4	
V-8	Voltage Regulator	0A2	
V-9	C.W. Oscillator	6J7	
V-10	Noise Limiter	6H6	
V-11	First Audio Amplifier	6SJ7	
V-12	Audio Output	6V6GT/G	
X-1	Crystal Selectivity Switch	Rotary	Two gang, 6 Position
X-2	A.V.C. Switch	Toggle	S.P.S.T.
X-3	B+ Switch	Toggle	S.P.S.T.
X-4	S-Meter Switch	Part of R-22	S.P.S.T.
X-5	C.W. Oscillator Switch	Part of C-25	S.P.S.T.
X-6	Limiter Switch	Part of R-27	S.F.D.T.
X-7	Tone Switch	Toggle	S.P.S.T.
X-8	Radio-Phono Switch	Rotary	D.P.D.T.
Y-1	Crystal Resonator	Quartz	456 Kc.
<b>TYPE 697 POWER UNIT</b>			
C-112,			
C-113	Filter Capacitor	Elec.	8+8+8 mfd., 475 VDCW
C-114			
L-102	Filter Choke	Potted	17 Henry
P-101	Power Cord and Plug		
S-101	115-230 Volt Switch	Toggle	D.P.D.T.
S-102	Power Switch	Toggle	S.P.S.T.
T-101	Power transformer	Potted	
V-101	Rectifier Tube	5Y3GT/G	
<b>TYPE 686S POWER UNIT</b>			
C-101	Filter Capacitor	Mica	500 mfd., 15 VDCW
C-102	Filter Capacitor	Elec.	8+8 mfd., 475 VDCW
C-103			
E-101	Vibrapack		6.3 VDC Input
F-101	Fuse	3AG	10 Amperes
L-201	Filter Choke	Potted	17 Henry
L-202	Hash Choke	Potted	
S-101	Power Switch	Toggle	S.P.S.T.
V-101	Rectifier Tube	6X5	

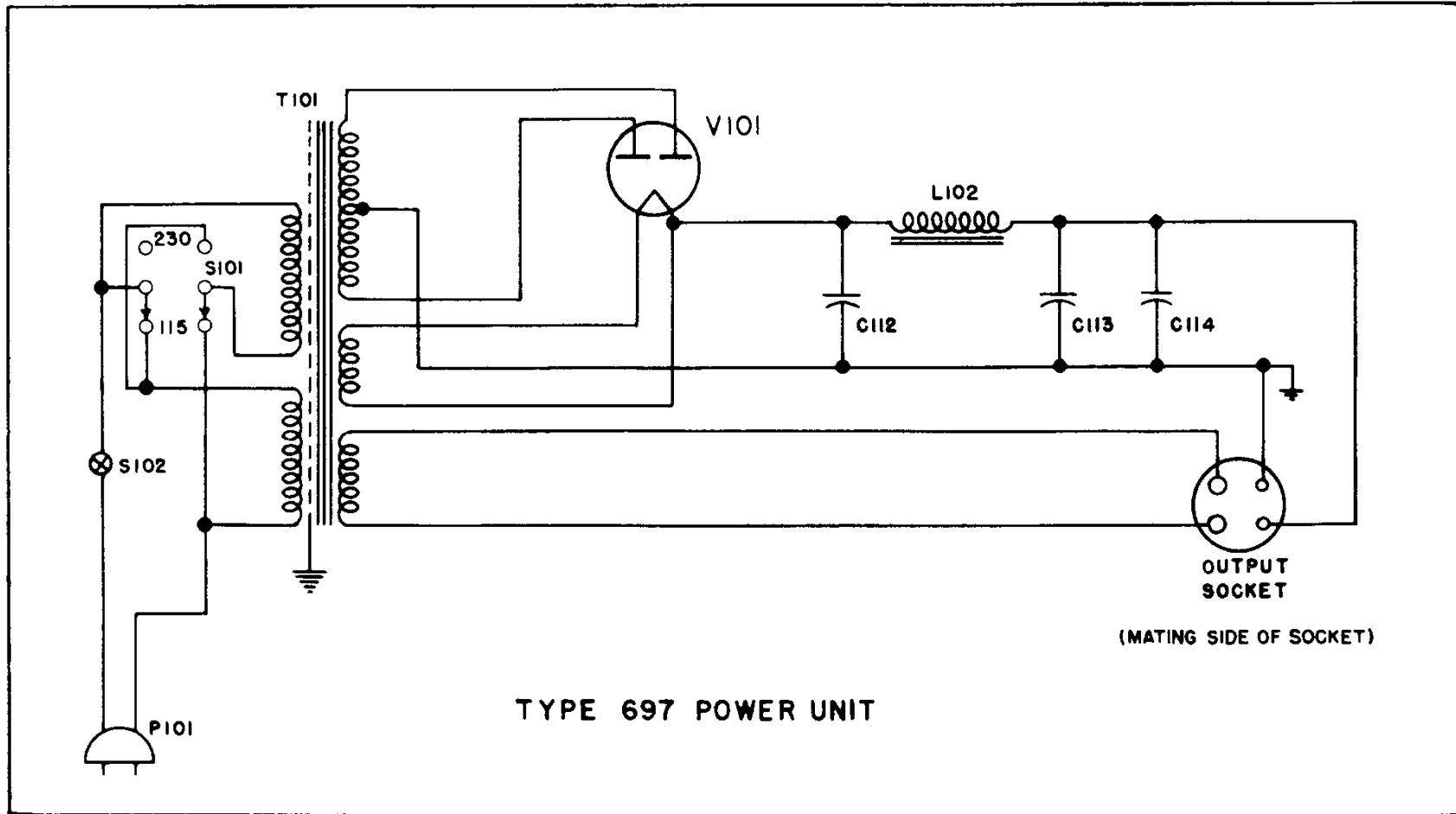

Figure No. 9. Schematic Diagram -- 697 Power Unit

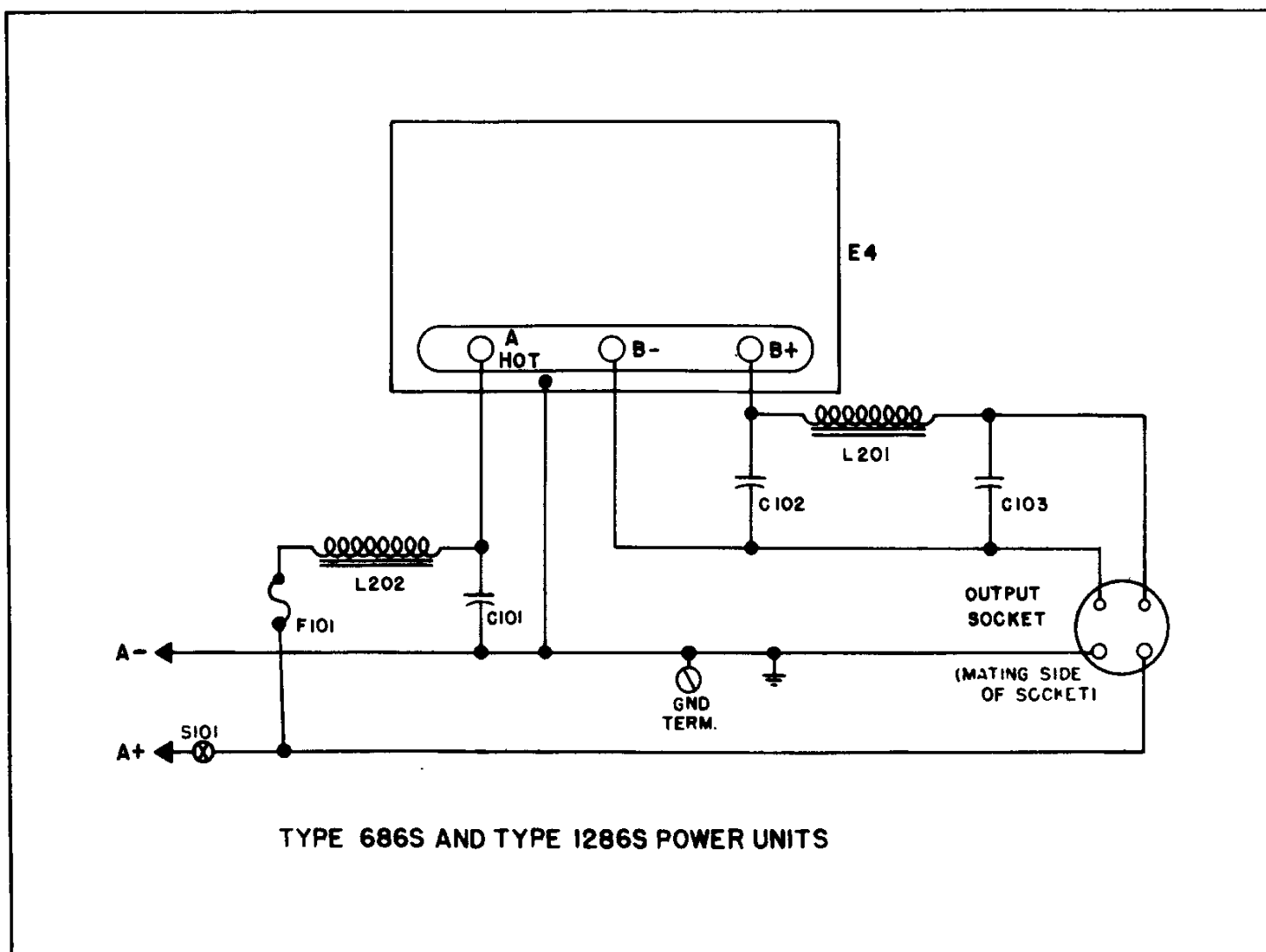

Figure No. 10. Schematic Diagram -- 686S Power Unit

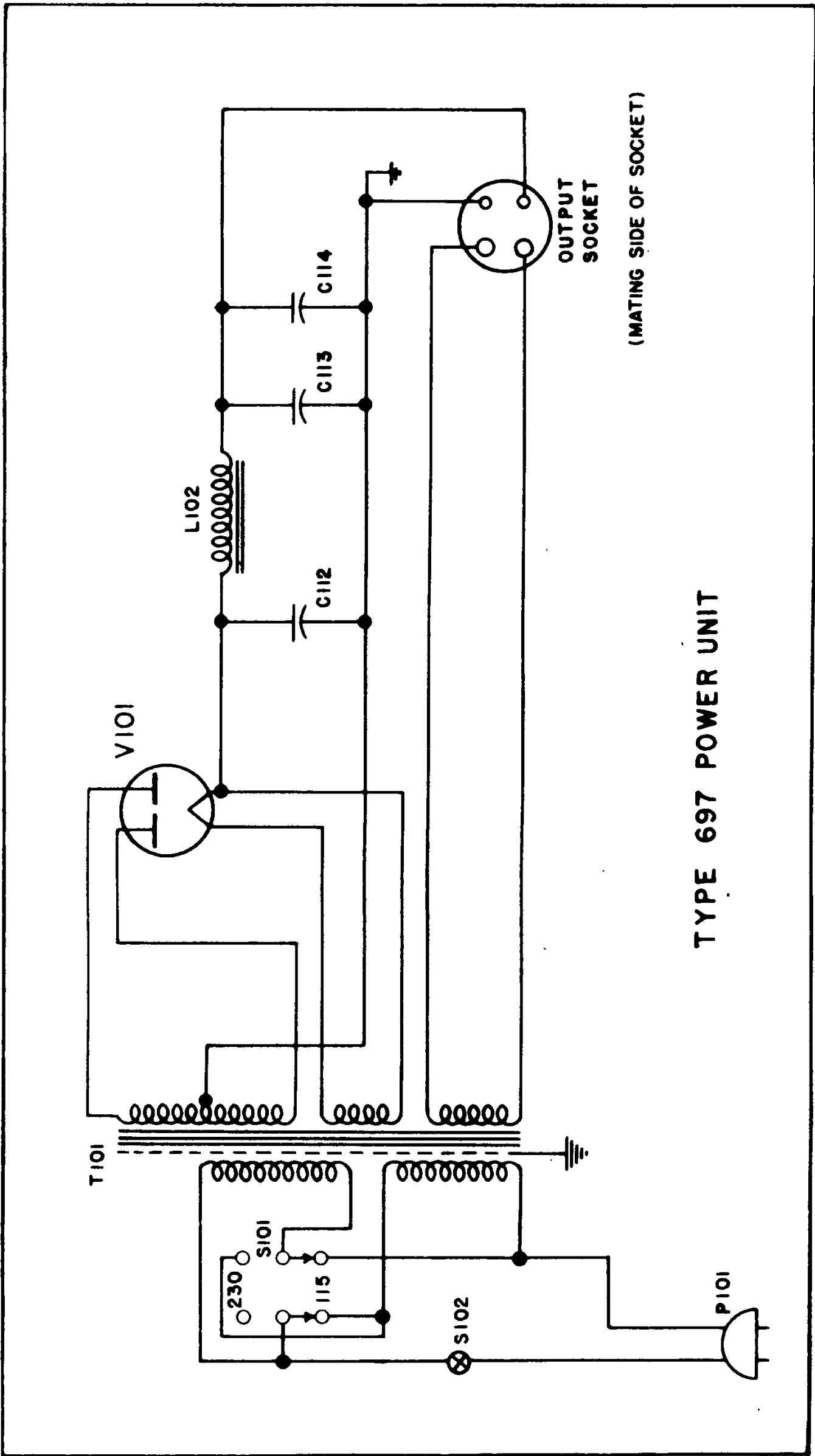

Figure No. 9. Schematic Diagram -- 697 Power Unit

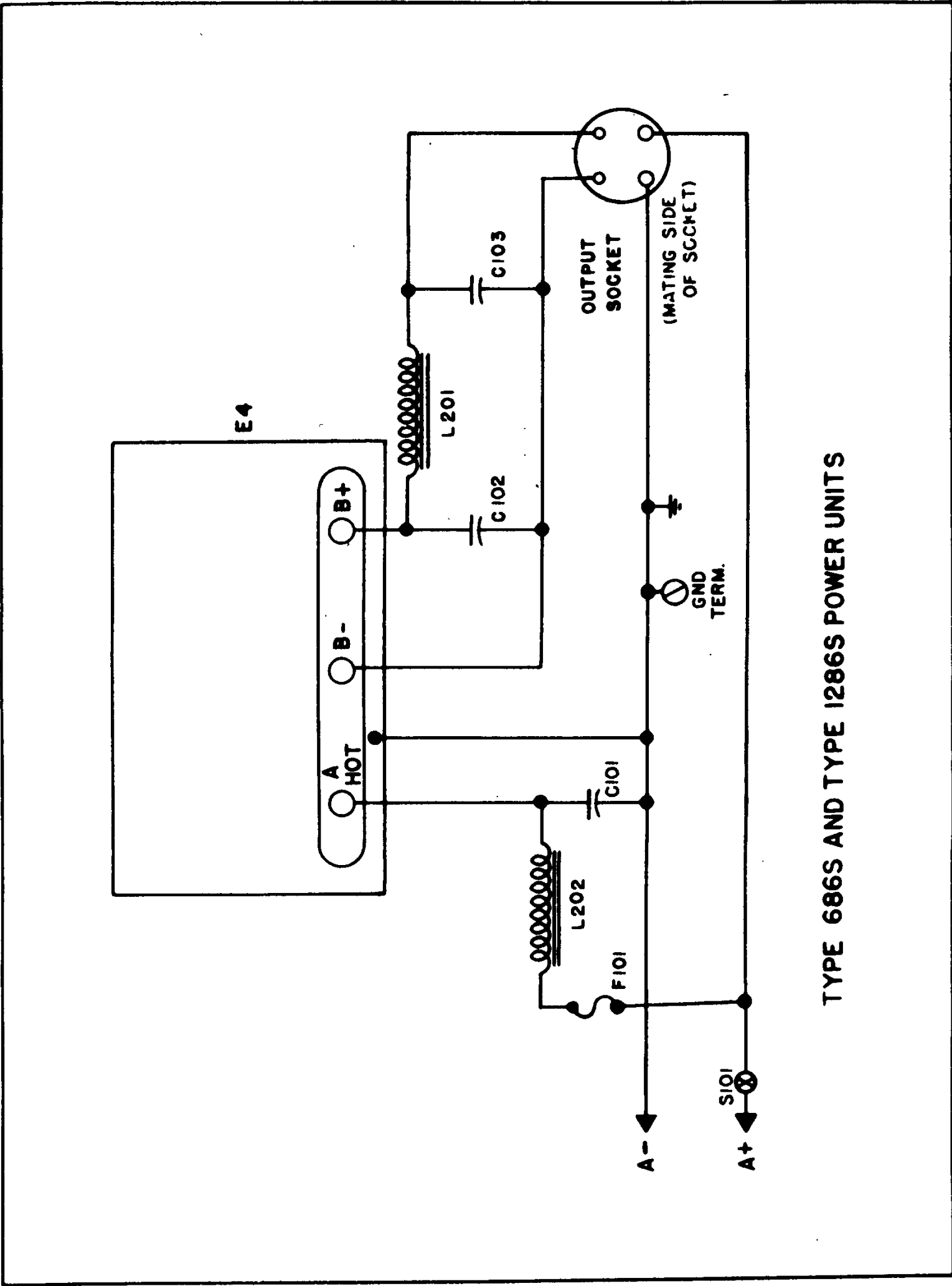

Figure No. 10. Schematic Diagram -- 686S Power Unit

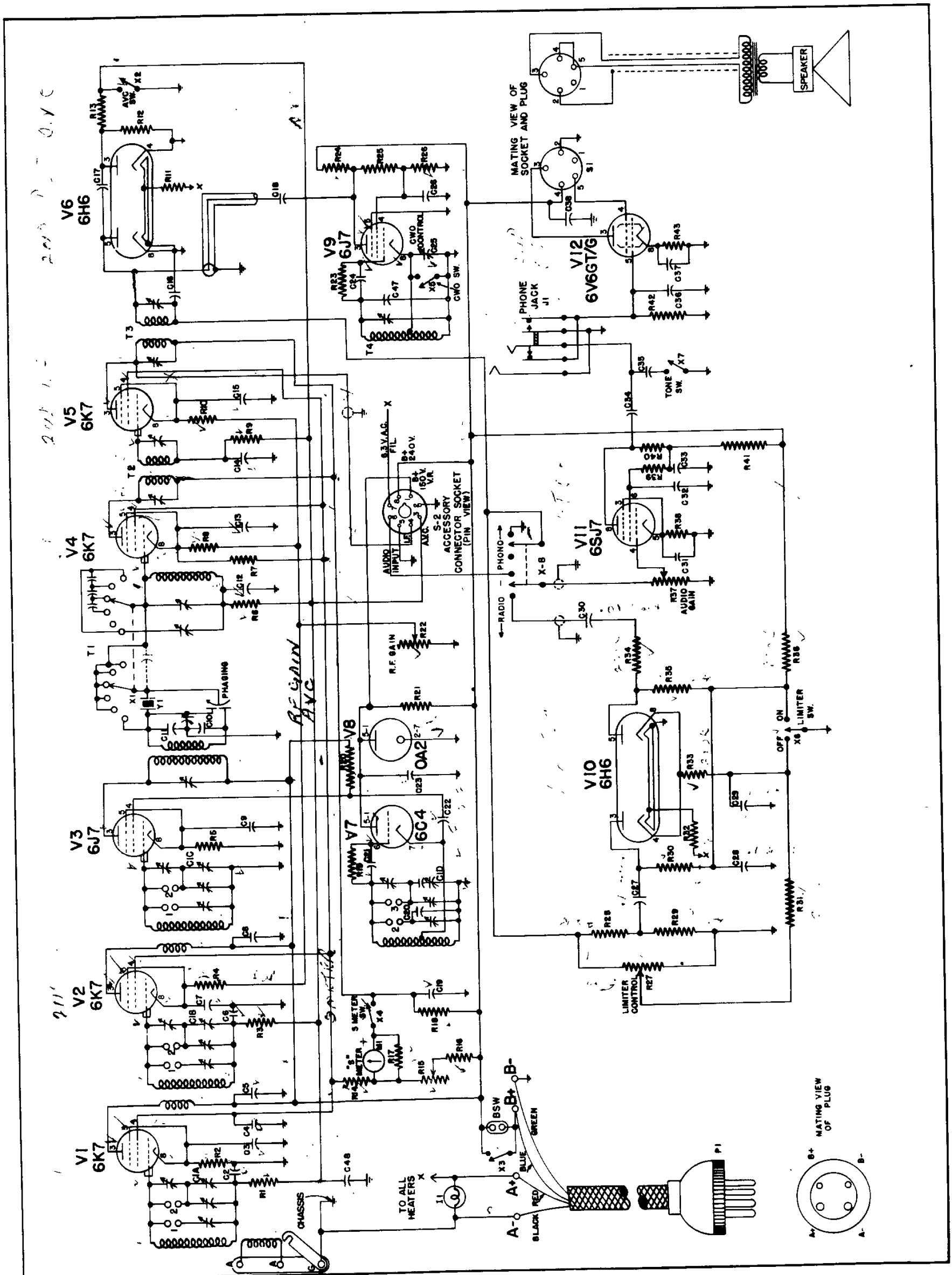

Figure No. 11. Schematic Diagram -- HRO-7 Radio Receiver

# THE NATIONAL HRO-7 RECEIVER

## ***PRICE LIST***

HRO-7T Receiver, table mounting gray finish, complete with tubes, crystal filter, noise limiter, and A, B, C, D, coil sets.

HRO-7R Receiver, same as above but mounted on a  $\frac{1}{8}$ " steel standard rack panel  $10\frac{1}{2}$ " high, black finish.

697 Power Unit, table mounting, 115 and 230 volt, 50/60 cycle operation.

SPU-697 Power Unit, same as above but mounted on  $5\frac{1}{4}$ " high rack panel, black finish.

686S Power Unit, table mounting, 6 volt battery operated vibrapack.

MCR Table Model 8" PM dynamic loudspeaker with matching transformer.

RFSH Loudspeaker, same as above but mounted on  $8\frac{3}{4}$ " high rack panel, black finish.

SPC Combination Unit, an installation consisting of a power unit, coil container and 8" PM dynamic loudspeaker mounted on a single rack panel  $15\frac{3}{4}$ " high.

MRR Mounting Rack, a standard 19" panel width table rack with a panel capacity  $26\frac{1}{4}$ " high. Trim strips included.

*Prices on Application*



**National Co., Inc., Malden, Mass., U. S. A.**

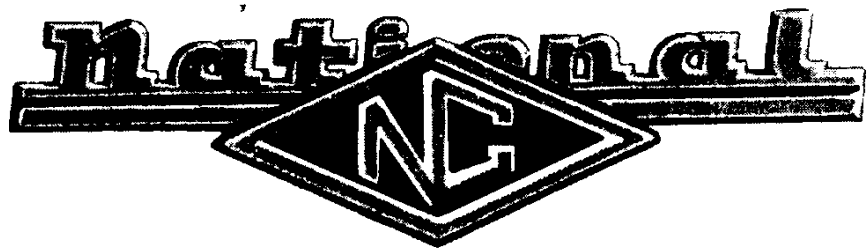

**NATIONAL COMPANY, INC.**  
**MALDEN, MASS.**  
**U. S. A.**